



**CITY OF ORANGE  
LOCAL IMPLEMENTATION PLAN (LIP)**

**SECTION A-5  
MUNICIPAL ACTIVITIES**



## SECTION A-5, MUNICIPAL ACTIVITIES

---

### A-5.0 MUNICIPAL ACTIVITIES

#### A-5.1 Introduction

The City has incorporated the Model Municipal Activities Program described in Section 5 of the DAMP as the basis for this section of the LIP. Subsequent sections describe and outline guidelines, procedures and requirements for the City for carrying out the Municipal Activities Program.

The Municipal Activities Program provides the framework and a process for conducting the following NPDES permit compliance activities at municipal fixed facilities, field programs and drainage facilities:

- Inventorying;
- Prioritization, based upon water quality threat;
- Identification of Model Maintenance Procedures and Best Management Practices (BMPs) to be implemented;
- Inspections and enforcement;
- Assessments of program effectiveness through implementation of a Program Effectiveness Assessment program; and
- Training for municipal staff, contractors, lessors and emergency fire service personnel.

In addition, the Municipal Activities Program has been integrated with the other storm water management programs presented within the DAMP so that the City is able to leverage its finite resources and benefit from the other program efforts. The program integration is illustrated in **Figure A-5.I**.



SECTION A-5, MUNICIPAL ACTIVITIES

**Figure A-5.I**  
**Storm Water Management Program Integration**

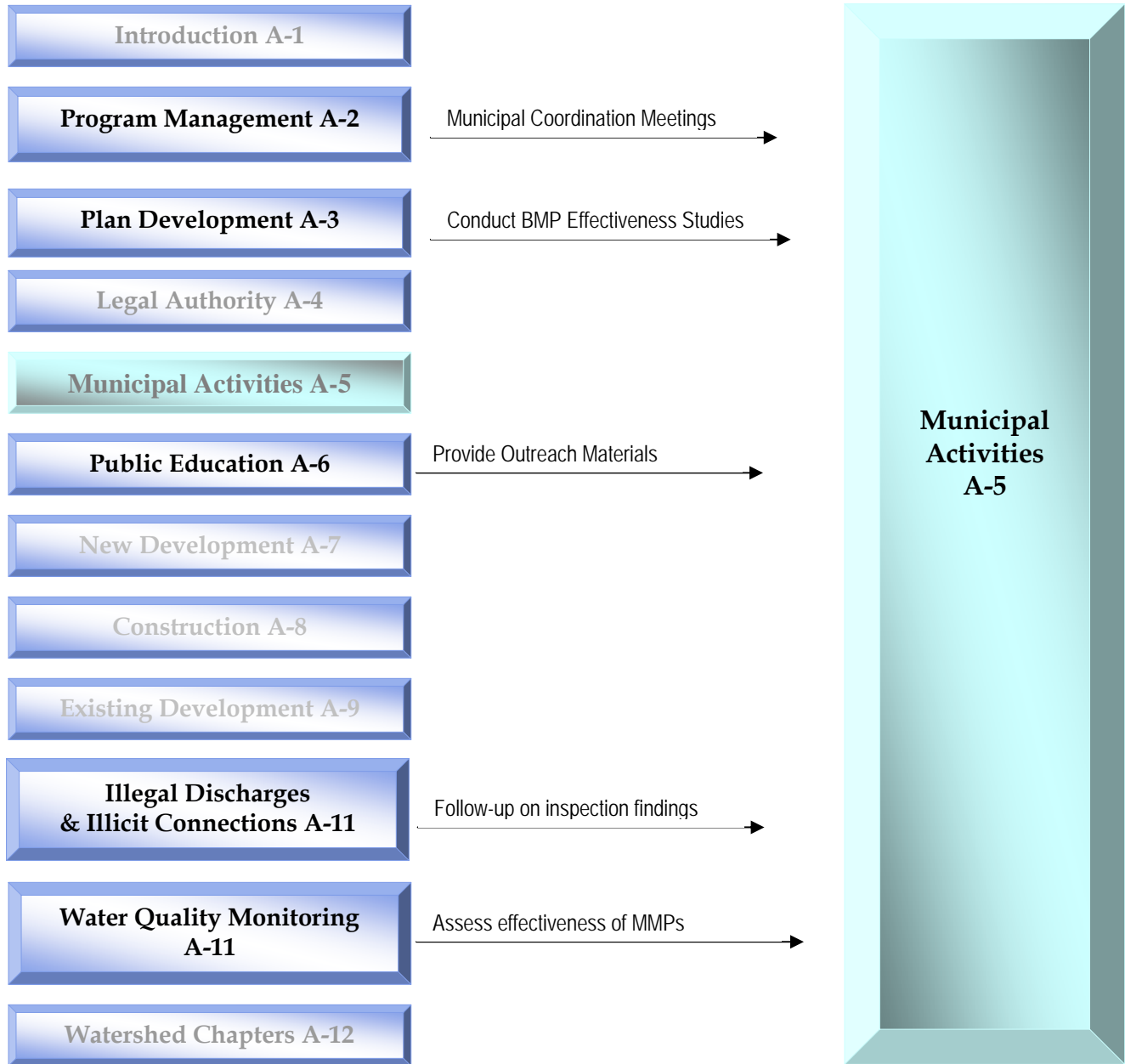



## SECTION A-5, MUNICIPAL ACTIVITIES

### A-5.1.1 Overall Program Management

The LIP has been developed to assist municipal staff in complying with Santa Ana Regional Board Orders. The program management model for overseeing, implementing, and enforcing the municipal activities stormwater program element is identified in **Figure A-5.II**.

**Figure A-5.II**  
**City of Orange Municipal Activities**  
**Program Management**

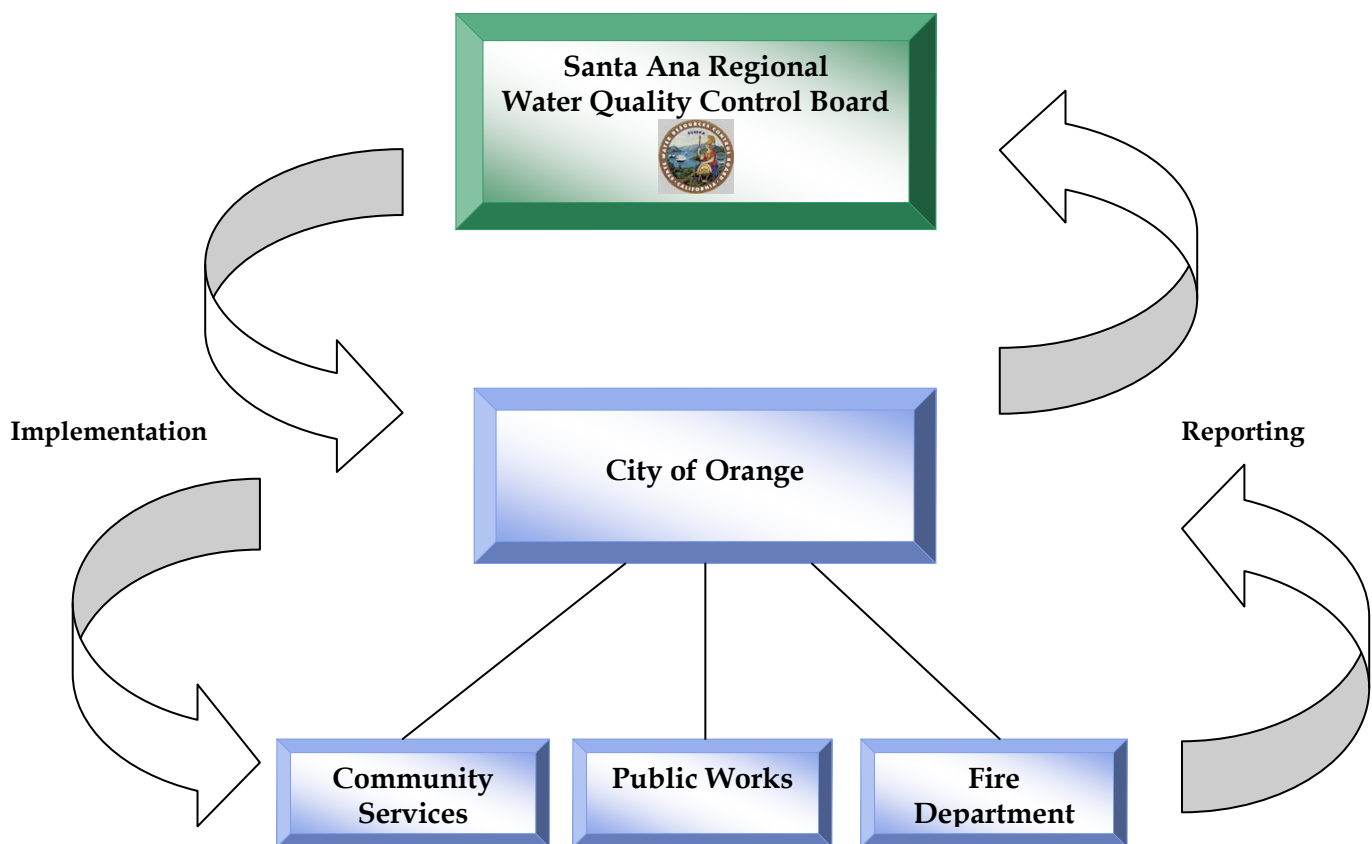



## SECTION A-5, MUNICIPAL ACTIVITIES

### A-5.1.2 Implementation

While the model municipal activities program will be implemented by every department in the City, the Public Works and Community Services Departments have primary responsibility for the overall operations and maintenance of fixed facilities, drainage facilities and field programs.

The responsibilities of the City departments for the implementation of the Municipal Activities Program element are shown below in **Table A-5.I**. Key staff names are shown in **Exhibit A-2.I**.

**Table A-5.I - City of Orange Municipal Activities Implementation**

Department	Activity	Responsibility Under the Order/ DAMP
Fixed Facilities		
Public Works/ Water	Operates and maintains municipal water facilities and water yard	Implements applicable BMPs, reports actions taken and modifications to LIP Mgmt.
Public Works/ Maintenance	Operates and maintains wastewater collection facilities	Implements applicable BMPs, reports actions taken and modifications to LIP Mgmt.
Public Works/ Maintenance	Operates and maintains corporate yards	Implements applicable BMPs, reports actions taken and modifications to LIP Mgmt.
Public Works/ Facilities Maintenance	Maintains community centers, libraries and recreational buildings	Implements applicable BMPs, reports actions taken and modifications to LIP Management
Community Services / Environmental	Operates and maintains parks, community centers, libraries and recreational facilities	Implements applicable BMPs, reports actions taken and modifications to LIP Management
Police	Operates and maintains police facilities	Implements applicable BMPs, reports actions taken and modifications to LIP Management
Fire	Operates and maintains fire stations	Implements applicable BMPs, reports actions taken and modifications to LIP Management



SECTION A-5, MUNICIPAL ACTIVITIES

Department	Activity	Responsibility Under the Order/ DAMP
Public Works/ Maintenance; Community Services/ Environmental	Operates and maintains public parking lots	Implements applicable BMPs, reports actions taken and modifications to LIP Management
<b>Field Programs</b>		
Finance; Public Works/ Maintenance	Establishes and maintains contracts for select field program services	Implement mechanism for ensuring that contractors adhere to the DAMP and implement applicable BMPs
Community Services	Manages and implements IPM, pesticide, fertilizer , and weed abatement programs	Implements applicable BMPs, reports actions taken and modifications to LIP Management
Community Services	Manages and implements landscape maintenance programs including lakes	Implements applicable BMPs, reports actions taken and modifications to LIP Management
Public Works/ Engineering	Plans, designs, and constructs projects related to roadway design & improvement	Implements applicable BMPs
Public Works/ Maintenance	Manages and implements street sweeping program; waste recycling and litter control programs; and operates and maintains municipal waste facilities	Implements applicable BMPs



SECTION A-5, MUNICIPAL ACTIVITIES

Department	Activity	Responsibility Under the Order/2003 DAMP
Public Works/ Water	Manages, operates and maintains municipal water facilities	Implements applicable BMPs
Drainage Facilities		
Public Works/ Engineering & Maintenance	Manages storm drain inventory/atlas	Updates or provides (GIS) with storm drain information to LIP Management
Public Works/ Maintenance	Operates and maintains storm drains and flood control facilities	Implements applicable model BMPs, reports actions taken and modifications to LIP Management
Public Works/ Maintenance	Maintains catch basins and stenciling program	Maintains catch basins and implements stenciling program; reports actions taken and program modifications to LIP Management
Fire/ Prevention	Weed abatement	Implements applicable BMPs, reports actions taken and modifications to LIP Management
All	Refer ordinance violations to LIP Management	Report violations of and/or enforce the water quality ordinance

**A-5.2 Inventory of Fixed Facilities, Field Programs, and Drainage Facilities**

An inventory of all fixed facility, field program, and drainage facility sites has been developed and is updated annually prior to the start of the wet season (October 1) and submitted as part of the City’s annual progress report. The inventory includes all sites meeting the definition of a fixed facility, field program, or drainage facility, as described in DAMP Section 5.2.1.

The City’s current fixed facility, field program and drainage facility inventories and GIS maps are included in **Exhibit A-5.I** to this LIP (for the most current see the latest annual report). The Exhibit includes the following:

- Fixed Facilities            Spreadsheet Inventory and GIS Map
- Field Programs            Spreadsheet Inventory
- Drainage Facilities        GIS Map



## SECTION A-5, MUNICIPAL ACTIVITIES

### A-5.3 Prioritization of Sites

The inventory of fixed facility sites is prioritized into high, medium, or low categories, based on the procedures set forth in the DAMP. After each inspection the facilities will be rescored according to DAMP criteria and a new priority category assigned if needed. The results of the current prioritization are included within the fixed facility inventory spreadsheet. The latest prioritizations will be presented in the annual progress report.

Drainage facilities (channels) are prioritized as high based on the potential threat to water quality.

### A-5.4 Maintenance Procedures

Staff performs operations at fixed facilities, within field programs, and at drainage facilities according to the procedures and Best Management Practices (BMPs) described within the Model Maintenance Procedures. Optional enhanced BMPs described within the Model Maintenance Procedures have been implemented at high priority fixed facilities, field programs, and drainage facilities if operational history, inspection findings, or other special situations warrant implementation. The City uses the Integrated Pest Management Guidelines of its IPM program **Exhibit A-5.IV**.

Model Maintenance Procedures relevant to the City's facilities and field programs are included in **Exhibit A-5.II**. The types of maintenance procedures that are used at the various fixed facilities, field programs and drainage facilities within the city are listed below in **Figure A-5.III**.

**Figure A-5.III**

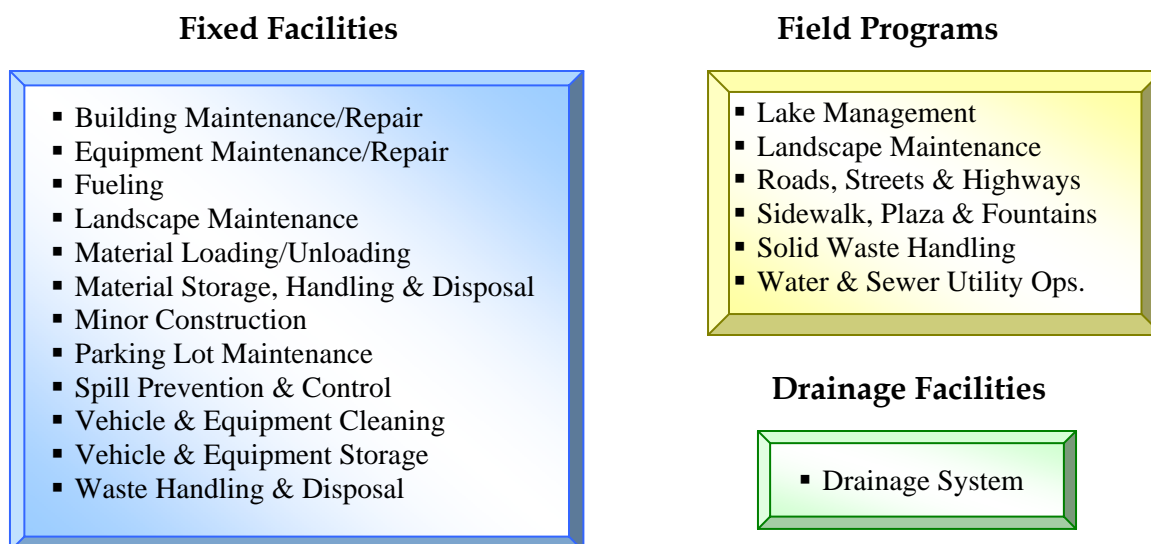





## SECTION A-5, MUNICIPAL ACTIVITIES

The City implements routine maintenance for its sewage collection system in accordance with State Board Water Quality Order No. 2006-0003. In addition, the City participates in the Countywide Area Spill Control (CASC) Program to minimize impacts of sewer spills in nearby water bodies.

### A-5.5 Municipal Inspection & Enforcement

#### A-5.5.1 Inspection Responsibilities

Inspections of municipal fixed facilities, field programs, and drainage facilities are performed in order to verify that the maintenance procedures are being implemented, are appropriate for that fixed facility, field program, or drainage facility and are protective of water quality.

Inspections are based upon the priority designation of the fixed facility, and its potential threat to water quality as indicated in the inventory spreadsheet included in **Exhibit A-5.I**. All drainage facilities are considered high priority. Inspection frequency is consistent, whether a facility or program is operated and maintained by City staff, contracted staff, or lessors.

#### A-5.5.2 Inspection Frequencies

The frequency of municipal facility and program inspections is shown in **Table A-5.II** below. However, in the event of an observed problem or detected non-storm water discharge, the inspection frequency may be increased as appropriate to facilitate the correction of the problem.

**Table A-5.II  
Inspection Frequencies**

Facility/Program	Inspection Frequency
<b>Fixed Facilities</b>	
Municipal Corporation Yards	Annually
High Priority Fixed Facility	Annually
Medium Priority Fixed Facility	Every Two Years During Permit Term
Low Priority Fixed Facility	Once During Permit Term
<b>Field Programs</b>	
High Priority Field Programs	Annually
<b>Drainage Facilities</b>	
Drainage Facilities (catch basins, storm drain inlets, open channels)	Annually (inspect ≥80% annually; 100% within 2-year period)

Municipal corporation yards will be inspected annually in accordance with the Fourth Term Permit. At least 80 percent of drainage facilities (catch basins, storm drain inlets and open



## SECTION A-5, MUNICIPAL ACTIVITIES

---

channels) will be inspected, cleaned, and maintained on an annual basis, with 100 percent of the facilities included in a two-year period.

### A-5.5.3 Inspection Documentation Procedures

The inspection forms that will be used during inspection consist of the following:

- **General Inspection Forms** – This primary form provides for a general characterization of the fixed facility, field program, or drainage facility being inspected, including the type of facility or program, the reason for inspection, and activities that may take place. A general cover sheet inspection form is required for all inspections.
- **Activity Specific Inspection Forms** – These secondary forms provide a series of questions about specific activities taking place at a fixed facility, field program, or drainage facility, as well as a list of suggested corrective action plans that can be implemented should a problem be found.

One activity specific form is filled out for each activity at each fixed facility, field program, or drainage facility. The inspection forms used to document inspections at each fixed facilities, field programs, and drainage facilities in the City are included in **Exhibit A-5.III**.

### A-5.5.4 Municipal Retrofitting

The City examines opportunities to retrofit existing MS4 conveyance systems, parks and other recreational areas, where feasible when projects are proposed in these facilities.

### A-5.5.5 Enforcement Procedures

In order to ensure compliance, the City will implement enforcement procedures as described in **DAMP Section 5.2.4.2**.

## **A-5.6 Model Integrated Pest Management, Pesticides and Fertilizer Guidelines**

The City has adopted an Integrated Pest Management (IPM) policy consistent with **DAMP Section 5.3**. The City's IPM policy is included in **Exhibit A-5.IV**.

The City will also conduct annual IPM self-audits in accordance with the adopted IPM policy.

## **A-5.7 Program Effectiveness Assessment**

The overall Program Effectiveness Assessment (PEA) serves as the foundation for the submittal of the annual progress report that is submitted each year to the Principal Permittee and subsequently to the Regional Boards and serves as the basis for evaluating each municipality's individual municipal activities efforts (See **DAMP Appendix C-5**).



## SECTION A-5, MUNICIPAL ACTIVITIES

---

The PEA allows the City to assess the effectiveness of its individual storm water program components including those focused on municipal activities. The municipal activities program effectiveness evaluation will allow the City to assess the effectiveness of its local program by focusing on the data collected from the fixed facility, field program and drainage facility activities.

### **A-5.8 Education and Training**

Education and training is the key to the success of storm water programs. To assist City staff in understanding the Municipal Activities Maintenance Procedures, several different annual training sessions will be conducted by the County of Orange. In order to ensure that the program is being implemented properly, the City will have the appropriate number and type of personnel attend each of the training sessions.

In addition to Permittee sponsored training, the City provides the means for staff to attend training seminars or workshops related to storm water management and water quality conducted by other organizations, as needed.

Records of both Permittee and Non-Permittee sponsored training provided to City staff are maintained.

#### A-5.8.1 Training Modules

In order to adequately address the different areas of the Municipal Activities Program element, municipal activities training modules have been developed as described in **DAMP Appendix B, Section B-5**. The following sections describe the modules.

##### *Municipal Activities Program Management*

This training module is targeted to staff responsible for managing the NPDES program for all municipal activities. It includes the tools necessary to meet NPDES requirements for inventorying, prioritizing, and inspecting municipal fixed facilities and field programs, as well as mechanisms for enforcement. An introduction to the Model Maintenance Procedures and Best Management Practices (BMPs) applicable to the program is provided. Training for program Performance Evaluation Assessment is also included.

##### *Fixed Facilities Maintenance Procedures*

This training module is targeted to staff responsible for performing and training proper maintenance procedures for municipal activities at fixed facilities (Corporation Yards, Waste Handling Facilities, etc.). It includes in-depth coverage of all program-applicable baseline Model Maintenance Procedures and Best Management Practices (BMPs), as well as optional procedures for use in special situations. The training provides information in a "train-the-



## SECTION A-5, MUNICIPAL ACTIVITIES

---

trainer” format, providing techniques for performing activities in a manner protective of water quality.

### *Field Program Maintenance Procedures*

This training module is targeted to staff responsible for performing and training proper maintenance procedures for municipal activities with field program (Street Maintenance, Drainage Facility Maintenance, etc.). It includes in-depth coverage of all program-applicable baseline Model Maintenance Procedures and Best Management Practices (BMPs), as well as optional procedures for use in special situations. The training provides information in a “train-the-trainer” format, providing techniques for performing activities in a manner protective of water quality.

### *Integrated Pest Management Policy*

The County of Orange, in conjunction with the U.C. Cooperative Extension, has developed a Model IPM program and will provide training as needed.

### *City Training*

The City has taken the County training modules for maintenance personnel and modified them accordingly to better fit the work conducted by the City.

### A-5.8.2 Record Keeping

Records of training provided to staff will be maintained to allow for a better determination of:

- Which staff require which training
- When training sessions were conducted
- Compliance with the permit requirements

Exhibit A-5.I

Fixed Facilities Map

Fixed Facilities

Drainage Facilities



# CITY OF ORANGE FIXED FACILITIES SITE MAP

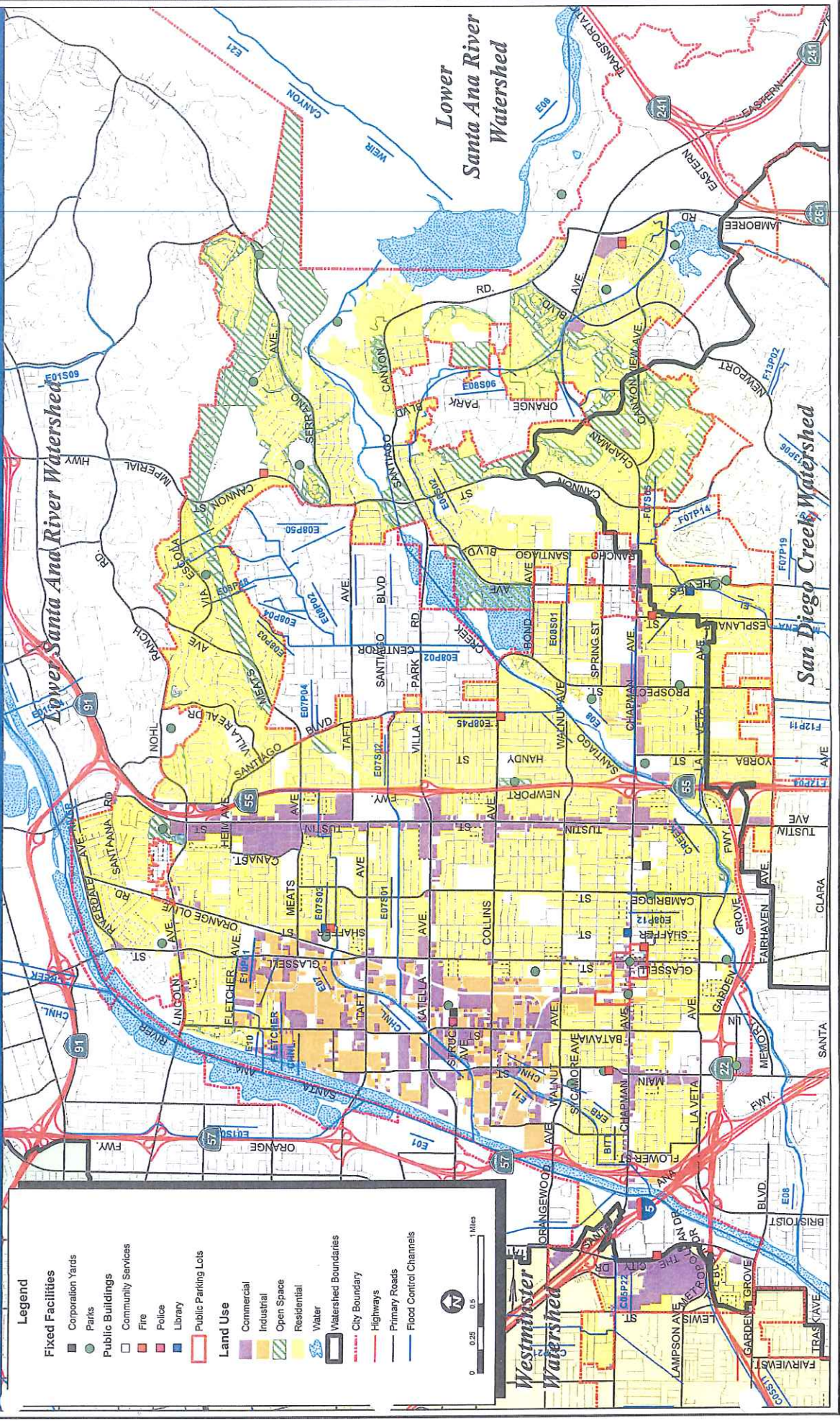

**Legend**

**Fixed Facilities**

- Corporation Yards
- Parks
- Public Buildings
- Community Services
- Fire
- Police
- Library
- Public Parking Lots

**Land Use**

- Commercial
- Industrial
- Open Space
- Residential
- Water

**Watershed Boundaries**

- City Boundary
- Highways
- Primary Roads
- Flood Control Channels

Scale: 0, 0.25, 0.5, 1 Miles



## City of Orange - Municipal Fixed Facility Inventory

Facility Name	Facility Physical Address Information			Watershed	Prioritization
	Street Number	Direction	Street Name		
<b>CORPORATION YARDS</b>					
CORP Yard - Maintenance	637	W	Struck	E - Lower Santa Ana River	High
Water Division (Public Works Dept)	189	S	Water	E - Lower Santa Ana River	High
<b>OTHER MUNICIPAL FACILITIES</b>					
<b>PARKS</b>					
Belmont Park	4536	E	Via Escola	E - Lower Santa Ana River	Medium
Community Gardens	1300	W	Maple	E - Lower Santa Ana River	Medium
Eisenhower Park	2894	N	Tustin	E - Lower Santa Ana River	Medium
El Camino Real Park	400	N	Main	E - Lower Santa Ana River	Medium
El Modena Basin	4343	E	Jordan	F - San Diego Creek	Medium
El Modena Park	555	S	Hewes	F - San Diego Creek	Medium
Fred Barrera Park	8380	E	Serrano	E - Lower Santa Ana River	Medium
Grijalva Park at Santiago Creek	368	N	Prospect	E - Lower Santa Ana River	Medium
Handy Park	2143	E	Oakmont	E - Lower Santa Ana River	Medium
Hart Park	701	S	Glassell	E - Lower Santa Ana River	Medium
Killefer Park	615	N	Lemon	E - Lower Santa Ana River	Medium
La Veta Park	3705	E	La Veta	E - Lower Santa Ana River	Medium
McPherson Sports Facility	333	S	Prospect	E - Lower Santa Ana River	Medium
Olive Park	2841	N	Glassell	E - Lower Santa Ana River	Medium
Plaza Park	100	W	Chapman	E - Lower Santa Ana River	Medium
Pitcher Park	206	S	Cambridge	E - Lower Santa Ana River	Medium
Santa Fe Depot Park	100	N	Atchinson	E - Lower Santa Ana River	Medium
Santiago Hills Park	8040	E	White Oak Ridge	E - Lower Santa Ana River	Medium
Serrano Park	2349	E	Apache Creek	E - Lower Santa Ana River	Medium
Shaffer Park	1930	N	Shaffer	E - Lower Santa Ana River	Medium
Yorba Park	190	S	Yorba	E - Lower Santa Ana River	Medium
<b>PUBLIC BUILDINGS</b>					
<i>Community Services</i>					
City Hall	300	E	Chapman	E - Lower Santa Ana River	Low
Community Services Annex	206	S	Center	E - Lower Santa Ana River	Low
City of Orange Resource Center	210	N	McPherson	E - Lower Santa Ana River	Low
City of Orange Senior Center	170	S	Olive	E - Lower Santa Ana River	Low
Friendly Stop & Rec. Center	615	N	Lemon	E - Lower Santa Ana River	Low
Friendly Center	147	W	Rose	E - Lower Santa Ana River	Low
Economic	230	E	Chapman	E - Lower Santa Ana River	Low
<i>Fire</i>					
Fire Station 1 (HDQRTS)	176	S	Grand	E - Lower Santa Ana River	Low
Fire Station 2	2900	E	Collins	E - Lower Santa Ana River	Low
Fire Station 3	1910	N	Shaffer	E - Lower Santa Ana River	Low
Fire Station 4	201	S	Esplanade	E - Lower Santa Ana River	Low
Fire Station 5	1345	W	Maple	E - Lower Santa Ana River	Low
Fire Station 6	345	S	City	Los Alamitos/East Garden	Low
Fire Station 7	8501	E	Fort	E - Lower Santa Ana River	Low
Fire Station 8	5725	E	Carver	E - Lower Santa Ana River	Low
Fire Prevention	174	S	Orange	E - Lower Santa Ana River	Low
<i>Police</i>					
Police Department (HDQTRS)	1107	N	Batavia	E - Lower Santa Ana River	Low
Police Substation	8525	E	Fort	E - Lower Santa Ana River	Low
<i>Library</i>					
Main Library	407	E	Chapman	E - Lower Santa Ana River	Low
El Modena Branch Library	380	S	Hewes	F - San Diego Creek	Low
Taft Branch Library	740	E	Taft	E - Lower Santa Ana River	Low
<b>Public Parking Lots</b>					
Metro Link West	503	W	Maple	E - Lower Santa Ana River	High
Metro Link East	184	N	Atchinson	E - Lower Santa Ana River	High
Lemon	140	N	Lemon	E - Lower Santa Ana River	High
No. Olive @ Maple	159	N	Olive	E - Lower Santa Ana River	High
No. Olive, so. of Maple	150	N	Olive	E - Lower Santa Ana River	High
N Orange @ E Maple	no address			E - Lower Santa Ana River	High
N Orange, S/O E Maple	no address			E - Lower Santa Ana River	High
Civic Center	no address			E - Lower Santa Ana River	High
S Grand, public side	no address			E - Lower Santa Ana River	High
Btwn Orange & Grand, S/O Chapman	no address			E - Lower Santa Ana River	High
So. Orange, so. of Chapman	no address			E - Lower Santa Ana River	High
So. Olive, east side	no address			E - Lower Santa Ana River	High
City of Orange Annex lot	326	E	Almond	E - Lower Santa Ana River	High
So. Olive, west side	144	S	Olive	E - Lower Santa Ana River	High

## City of Orange - Municipal Fixed Facility Inventory

<i>Park Parking Lots</i>					
Belmont Park	4536	E	Via Escola	E - Lower Santa Ana River	High
Community Gardens	1300	W	Maple	E - Lower Santa Ana River	High
Eisenhower Park	2894	N	Tustin	E - Lower Santa Ana River	High
El Camino Real Park	400	N	Main	E - Lower Santa Ana River	High
El Modena Basin	4343	E	Jordan	F - San Diego Creek	High
El Modena Park	555	S	Hewes	F - San Diego Creek	High
Fred Barrera Park	8380	E	Serrano	E - Lower Santa Ana River	High
Grijalva Park at Santiago Creek	368	N	Prospect	E - Lower Santa Ana River	High
Handy Park	2143	E	Oakmont	E - Lower Santa Ana River	High
Hart Park	701	S	Glassell	E - Lower Santa Ana River	High
Killefer Park	615	N	Lemon	E - Lower Santa Ana River	High
La Veta Park	3705	E	La Veta	E - Lower Santa Ana River	High
McPherson Sports Facility	333	S	Prospect	E - Lower Santa Ana River	High
Olive Park	2841	N	Glassell	E - Lower Santa Ana River	High
Plaza Park	100	W	Chapman	E - Lower Santa Ana River	High
Pitcher Park	206	S	Cambridge	E - Lower Santa Ana River	High
Santa Fe Depot Park	100	N	Atchinson	E - Lower Santa Ana River	High
Santiago Hills Park	8040	E	White Oak Ridge	E - Lower Santa Ana River	High
Serrano Heights Park	2349	E	Apache Creek	E - Lower Santa Ana River	High
Shaffer Park	1930	N	Shaffer	E - Lower Santa Ana River	High
Yorba Park	190	S	Yorba	E - Lower Santa Ana River	High





## City Channels

### Channel Name

Walnut Channel

Tustin/Wanda Channel

James Channel

Trenton Channel

Channel 5

Parts of Handy Creek



## Exhibit A-5.II

### Model Maintenance Procedures

**EXHIBIT A-5.II**

**CITY OF ORANGE**  
**MUNICIPAL ACTIVITIES**  
**MAINTENANCE PROCEDURES**

**Fixed Facilities**

- **Building Maintenance/Repair**
- **Equipment Maintenance/Repair**
- **Fueling**
- **Landscape Maintenance**
- **Material Loading/Unloading**
- **Material Storage, Handling and Disposal**
- **Minor Construction**
- **Parking Lot Maintenance**
- **Spill Prevention & Control**
- **Vehicle & Equipment Cleaning**
- **Vehicle & Equipment Storage**
- **Waste Handling & Disposal**

**Field Programs**

- **Lake Management**
- **Landscape Maintenance**
- **Roads, Streets & Highways**
- **Sidewalk, Plaza & Fountains**
- **Solid Waste Handling**
- **Water & Sewer Utilities**
- **Fire Department Activities**

**Drainage Facilities**

- **Drainage System**



## **BUILDING MAINTENANCE AND REPAIR**

**Stormwater runoff from building repair, remodeling, and other maintenance activities can be contaminated with toxic hydrocarbons in solvents, other toxic organic compounds, suspended solids, heavy metals, abnormal pH, and oils and greases. Specific activities may involve one or more of the following:**

- 1. Building Maintenance**
- 2. Material Storage**
- 3. Building Cleaning**
- 4. Graffiti Cleaning**
- 5. Painting**

### **POLLUTION PREVENTION:**

Pollution prevention measures have been considered and incorporated in the procedures. Implementation of these measures may be more effective and reduce or eliminate the need to implement other more complicated or costly procedures. Possible pollution prevention measures for building maintenance and repair include:

- Use dry cleaning methods whenever feasible.
- Use a waterless and non-toxic chemical cleaning method for graffiti removal.
- Educate municipal staff on pollution prevention measures.

## MODEL PROCEDURES:

### 1. Building Maintenance

#### General Guidelines

*See Minor Construction procedure sheet*

- ✓ Review maintenance activities to verify that they minimize the amount of pollutants discharged. Keep accurate maintenance logs to evaluate materials removed and improvements made.
- ✓ If when repairing roofs, small particles have accumulated in the gutter, either sweep out the gutter or wash the gutter and trap the particles at the outlet of the downspout. A sock or geofabric placed over the outlet may effectively trap the materials. If the downspout is tight lined, place a temporary plug at the first convenient point in the storm drain and pump out the water with a vactor truck and clean the storm drain inlet where you placed the plug if necessary.
- ✓ If water is used for cleaning out gutters, seal storm drain inlets to prevent water from entering. Either direct the water to a landscaped area or dispose of properly.
- ✓ When the work involves exposing large areas of soil, employ the appropriate soil erosion and control techniques.
- ✓ Clean storm drain inlets in the immediate vicinity of the construction activity after it is completed if necessary.

#### OPTIONAL:

- Recycle residual paints, solvents, lumber, and other materials

#### Good Housekeeping

- ✓ Keep the work site clean and orderly. Remove debris in a timely fashion. Sweep the area.
- ✓ Cover materials of particular concern that must be left out, particularly during the rainy season.
- ✓ Do not dump waste liquids down the storm drain.
- ✓ Properly dispose of wash water, sweepings, and sediments; do not allow these materials to enter the storm drain.

#### Spill Response

*Also see Spill Prevention and Control procedure sheet*

- ✓ Clean up spills immediately.
- ✓ If a spill occurs on dirt, excavate and remove the contaminated (stained) soil.

## 2. Material Storage

*Also see Material Storage/  
Handling/ Disposal procedure  
sheet*

- ✓ Properly store and cover materials that are normally used in repair and remodeling such as paints and solvents, to protect them from rain.
- ✓ Properly store and dispose waste generated from the activity.

## 3. Building Cleaning

### General Guidelines

→ *Note: Permission must be obtained for any discharge of wash water to the sanitary sewer from the local sewerage agency.*

- ✓ When cleaning building exteriors and walls composed of glass, steel, or painted surfaces with no lead or mercury:
  - Capture wash water to prevent entrance into the storm drain
  - When washing without soap, discharges can be directed to landscaped or dirt areas
  - When washing with soap, direct discharges to the sanitary sewer if permitted to do so or vacuum/pump water to a tank and dispose of properly
- ✓ When washing building exteriors painted with lead-based or mercury additive paint:
  - Capture wash water to prevent entrance into the storm drain
  - Vacuum/pump discharges to a tank
  - Dispose of as a hazardous waste as needed
- ✓ When acid washing mineral deposits:
  - Capture wash water to prevent entrance into the storm drain
  - Rinse treated area with alkaline soap and direct washwater to a landscaped or dirt area
  - Alternatively, washwater may be collected and neutralized to a pH between 6 and 8, and disposed of properly.

#### OPTIONAL:

- If cleaning agents are used, select biodegradable products whenever feasible.

## 4. Graffiti Cleaning

### Graffiti Removal

*Also see Roads, Streets, and Highways Operation and Maintenance procedure sheet.*

- ✓ Avoid graffiti abatement activities during rain events.
- ✓ When graffiti is removed by painting over, implement the procedures under Painting and Paint Removal in the *Roads, Streets, and Highway Operation and Maintenance* procedure sheet.
- ✓ Protect nearby storm drain inlets prior to removing graffiti from walls, signs, sidewalks, or other structures needing graffiti abatement. Clean up afterwards by sweeping or vacuuming thoroughly, and/or by using absorbent and properly disposing of the absorbent.
- ✓ Note that care should be taken when disposing of waste since it may need to be disposed of as hazardous waste.

#### OPTIONAL:

- Consider using a waterless and non-toxic chemical cleaning method for graffiti removal (e.g. gels or spray compounds).

## 5. Painting

### General Guidelines

- ✓ Develop paint handling procedures for proper use, storage, and disposal of paints.
- ✓ Painting operations should be properly enclosed or covered to avoid drift.
- ✓ If transporting paint and materials to and from job sites, use containers with secure lids and tie down to the transport vehicle.
- ✓ Test and inspect spray equipment prior to starting to paint. Tighten all hoses and connections and do not overfill paint container.
- ✓ Mix paint indoors before using so that any spill will not be exposed to rain. Do so even during dry weather because cleanup of a spill will never be 100% effective.
- ✓ Transfer and load paint and hot thermoplastic away from storm drain inlets.
- ✓ Replace paints containing lead or tributyltin with less toxic alternatives.
- ✓ Where there is significant risk of a spill reaching storm drains, plug nearby storm drain inlets prior to starting painting and remove plugs when job is complete.
- ✓ If sand blasting is used to remove paint, cover nearby storm drain inlets prior to starting work and collect wash water and dispose of properly.
- ✓ If painting requires scraping or sand blasting of the existing surface, use a ground cloth to collect the chips. Dispose of the residue properly.
- ✓ If using water based paints, clean the application equipment in a sink that is connected to the sanitary sewer.
- ✓ Brushes and tools covered with non-water-based paints, finishes, or other



materials must be cleaned in a manner that enables collection of used solvents (e.g., paint thinner, turpentine, etc.) for recycling or proper disposal. Waste solvents or oil based paints must be disposed of as hazardous waste.

## Paint Disposal

- ✓ Paints containing lead or tributyl tin are considered a hazardous waste and must be disposed of at an appropriate hazardous waste facility.
- ✓ Properly store leftover paints if they are to be kept for the next job.

### OPTIONAL:

- Recycle paint whenever possible.

---

## LIMITATIONS:

Safer alternative products may not be available, suitable, or effective in every case.

## REFERENCES:

*California Storm Water Best Management Practice Handbooks. Municipal Best Management Practice Handbook. Prepared by Camp Dresser & McKee, Larry Walker Associates, Uribe and Associates, Resources Planning Associates for Stormwater Quality Task Force. March 1993.*

Model Urban Runoff Program: A How-To Guide for Developing Urban Runoff Programs for Small Municipalities. Prepared by City of Monterey, City of Santa Cruz, California Coastal Commission, Monterey Bay National Marine Sanctuary, Association of Monterey Bay Area Governments, Woodward-Clyde, Central Coast Regional Water Quality Control Board. July. 1998.

Oregon Association of Clean Water Agencies. Oregon Municipal Stormwater Toolbox for Maintenance Practices. June 1998.

Santa Clara Valley Urban Runoff Pollution Prevention Program. 1997 Urban Runoff Management Plan. September 1997, updated October 2000.

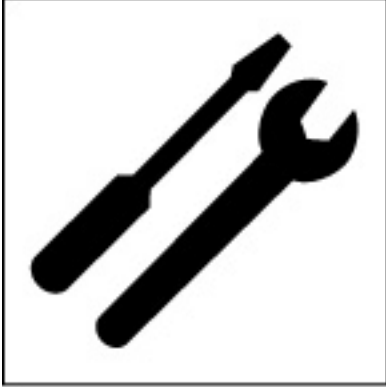

## EQUIPMENT MAINTENANCE AND REPAIR

**Vehicle or equipment maintenance has the potential to be a significant source of stormwater pollution. Engine repair and service (parts cleaning, spilled fuel, oil, etc.), replacement of fluids, and outdoor equipment storage and parking (dripping engines) can all contaminate stormwater. Conducting the following activities in a controlled manner will reduce the potential for stormwater contamination:**

- 1. General Maintenance and Repair**
- 2. Vehicle and Machine Repair**
- 3. Waste Handling/Disposal**

**Related vehicle maintenance activities are covered under the following program headings in this manual: “Vehicle and Equipment Cleaning”, “Vehicle and Equipment Storage”, and “Vehicle Fueling”.**

### **POLLUTION PREVENTION:**

Pollution prevention measures have been considered and incorporated in the procedures. Implementation of these measures may be more effective and reduce or eliminate the need to implement other more complicated or costly procedures. Possible pollution prevention measures for equipment maintenance and repair include:

- Review maintenance activities to verify that they minimize the amount of pollutants discharged to receiving waters. Keep accurate maintenance logs to evaluate materials removed and improvements made.
- Switch to non-toxic chemicals for maintenance when possible.
- Choose cleaning agents that can be recycled.
- Minimize use of solvents. Clean parts without using solvents whenever possible. Recycle used motor oil, diesel oil, and other vehicle fluids and parts whenever possible.
- Educate municipal staff on pollution prevention measures.

## MODEL PROCEDURES:

### 1. General Maintenance and Repair

#### General Guidelines

→ *Note: Permission must be obtained for any discharge of wash water to the sanitary sewer from the local sewerage agency.*

- ✓ Review maintenance activities to verify that they minimize the amount of pollutants discharged to receiving waters. Keep accurate maintenance logs to evaluate materials removed and improvements made.
- ✓ Regularly inspect vehicles and equipment for leaks.
- ✓ Move activity indoors or cover repair area with a permanent roof if feasible.
- ✓ Minimize contact of stormwater with outside operations through berming and drainage routing.
- ✓ Place curbs around the immediate boundaries of the process equipment.
- ✓ Clean yard storm drain inlets regularly and stencil them.

#### Good Housekeeping

→ *Note: Permission must be obtained for any discharge of wash water to the sanitary sewer from the local sewerage agency.*

- ✓ Avoid hosing down work areas. If work areas are washed and if discharge to the sanitary sewer is allowed, treat water with an appropriate treatment device (e.g. clarifier) before discharging. If discharge to the sanitary sewer is not permitted, pump water to a tank and dispose of properly.
- ✓ Collect leaking or dripping fluids in drip pans or containers. Fluids are easier to recycle or dispose of properly if kept separate.
- ✓ Keep a drip pan under the vehicle while you unclip hoses, unscrew filters, or remove other parts. Place a drip pan under any vehicle that might leak while you work on it to keep splatters or drips off the shop floor.
- ✓ Educate employees on proper handling and disposal of engine fluids.
- ✓ Promptly transfer used fluids to the proper waste or recycling drums. Don't leave full drip pans or other open containers lying around.
- ✓ Do not pour liquid waste to floor drains, sinks, outdoor storm drain inlets, or other storm drains or sewer connections.
- ✓ Post signs at sinks and stencil outdoor storm drain inlets.

## 2. Vehicle Repair

### General Guidelines

*Also see Waste Handling procedure sheet*

- ✓ Perform vehicle fluid removal or changing inside or under cover where feasible to prevent the run-on of stormwater and the runoff of spills.
- ✓ Regularly inspect vehicles and equipment for leaks, and repair as needed.
- ✓ Use secondary containment, such as a drain pan or drop cloth, to catch spills or leaks when removing or changing fluids.
- ✓ Immediately drain all fluids from wrecked vehicles. Ensure that the drain pan or drip pan is large enough to contain drained fluids (e.g. larger pans are needed to contain antifreeze, which may gush from some vehicles).
- ✓ Promptly transfer used fluids to the proper waste or recycling drums. Don't leave full drip pans or other open containers lying around.
- ✓ Recycle used motor oil, diesel oil, and other vehicle fluids and parts whenever possible.
- ✓ Oil filters disposed of in trash cans or dumpsters can leak oil. Place the oil filter in a funnel over a waste oil recycling drum to drain excess oil before disposal. Oil filters can also be recycled. Ask your oil supplier or recycler about recycling oil filters.
- ✓ Store cracked batteries in a non-leaking secondary container and dispose of properly at recycling or household hazardous waste facilities.

### Vehicle Leak and Spill Control

- ✓ Use absorbent materials on small spills. Remove the absorbent materials promptly and dispose of properly.
- ✓ Place a stockpile of spill cleanup materials where it will be readily accessible.
- ✓ Sweep floor using dry absorbent material.

## 3. Machine Repair

*Also see the Spill Prevention and Control procedure sheet*

- ✓ Keep equipment clean; don't allow excessive build-up of oil or grease.
- ✓ Minimize use of solvents.
- ✓ Use secondary containment, such as a drain pan or drop cloth, to catch spills or leaks when removing or changing fluids.
- ✓ Perform major equipment repairs at the corporation yard, when practical.
- ✓ Following good housekeeping measures in *Vehicle Repair* section.

## 4. Waste Handling/Disposal

### Waste Reduction

- ✓ Prevent spills and drips of solvents and cleansers to the shop floor.
- ✓ Do liquid cleaning at a centralized station so the solvents and residues stay in one area. Recycle liquid cleaners when feasible.
- ✓ Locate drip pans, drain boards, and drying racks to direct drips back into a solvent sink or fluid holding tank for reuse.

### Safer Alternatives

#### OPTIONAL:

- If possible, eliminate or reduce the amount of hazardous materials and waste by substituting non-hazardous or less hazardous material:
  - Use non-caustic detergents instead of caustic cleaning for parts cleaning.
  - Use a water-based cleaning service and have tank cleaned. Use detergent-based or water-based cleaning systems in place of organic solvent degreasers.
  - Replace chlorinated organic solvents with non-chlorinated solvents. Non-chlorinated solvents like kerosene or mineral spirits are less toxic and less expensive to dispose of properly. Check list of active ingredients to see whether it contains chlorinated solvents.
  - Choose cleaning agents that can be recycled.

### Recycling

#### OPTIONAL:

*Also see Waste Handling procedure sheet*

- Separate wastes for easier recycling. Keep hazardous and non-hazardous wastes separate, do not mix used oil and solvents, and keep chlorinated solvents separate from non-chlorinated solvents.
- Label and track the recycling of waste material (e.g. used oil, spent solvents, batteries).
- Purchase recycled products to support the market for recycled materials.

---

## LIMITATIONS:

Space and time limitations may preclude all work being conducted indoors. It may not be possible to contain and clean up spills from vehicles/equipment brought on-site after working hours. Dry floor cleaning methods may not be sufficient for some spills – see spill prevention and control procedures sheet. Identification of engine leaks may require some use of solvents.

## REFERENCES:

*California Storm Water Best Management Practice Handbooks. Municipal Best Management Practice Handbook. Prepared by Camp Dresser & McKee, Larry Walker Associates, Uribe and Associates, Resources Planning Associates for Stormwater Quality Task Force. March 1993.*

King County Stormwater Pollution Control Manual. Best Management Practices for Businesses. 1995. King County Surface Water Management. July. On-line: <http://dnr.metrokc.gov/wlr/dss/spcm.htm>

Model Urban Runoff Program: A How-To Guide for Developing Urban Runoff Programs for Small Municipalities. Prepared by City of Monterey, City of Santa Cruz, California Coastal Commission, Monterey Bay National Marine Sanctuary, Association of Monterey Bay Area Governments, Woodward-Clyde, Central Coast Regional Water Quality Control Board. July. 1998.



**FF-4**

## **FUELING**

**Spills and leaks that may occur during equipment and vehicle fueling can contribute hydrocarbons, oils and greases, and heavy metals to stormwater runoff. Implementation of the following procedures can help prevent fuel spills and leaks and thereby reduce their impacts to stormwater.**

### **POLLUTION PREVENTION:**

Pollution prevention measures have been considered and incorporated in the procedures. Implementation of these measures may be more effective and reduce or eliminate the need to implement other more complicated or costly procedures. Possible pollution prevention measures for fueling include:

- Fuel vehicles and equipment at off-site commercial fueling stations when feasible.
- Educate municipal staff on pollution prevention measures.

### **MODEL PROCEDURES:**

#### **General Guidelines**

→ *Note: Permission must be obtained for any discharge of wash water to the sanitary sewer from the local sewerage agency.*

- ✓ If refueling must be done on site, use a location away from storm drains and creeks.
- ✓ If re-developing the fueling area, design the area to prevent the run-on of stormwater and the runoff of spills:
  - Pave fueling area with Portland cement concrete (or equivalent smooth impervious surface), with a 2% to 4% slope to prevent ponding.
  - Separate the dispensing area from the rest of the site by a grade break that prevents run-on of storm water to the extent practicable. The fuel dispensing area is defined as extending 6.5 feet from the corner of each fuel dispenser or the length at which the hose and nozzle assembly area may be operated plus 1 foot, whichever is less. The paving around the fuel dispensing area may exceed the minimum dimensions of the “fuel dispensing area” stated above.

## FF-4

- Cover the fuel dispensing area. The cover's minimum dimensions must be equal to or greater than the area within the grade break or the fuel dispensing area.
- Design the cover so that it does not drain onto the fuel dispensing area.
- ✓ Install vapor recovery nozzles to help control drips as well as air pollution.
- ✓ Discourage "topping off" of fuel tanks.
- ✓ Use secondary containment such as curbs, berms, etc. when transferring fuel from the tank truck to the fuel tank.
- ✓ If the facility has large numbers of mobile equipment working throughout the site and they are fueled with a mobile fuel truck, establish a designated area for fueling. With the exception of racked equipment such as bulldozers and perhaps small forklifts, most vehicles should be able to travel to a designated area with little lost time. Place temporary "caps" over nearby storm drain inlets so that if a spill occurs it is prevented from entering the storm drain.
- ✓ Ensure compliance with all Federal and State requirements regarding underground storage tanks, or install above ground tanks.
- ✓ Use dry methods to clean the fueling area whenever possible. If you periodically clean by pressure washing, place a temporary plug in the downstream drain and pump out the accumulated water. Properly dispose of the water.
- ✓ Train employees on proper fueling and cleanup procedures
- ✓ Ensure the following safeguards are in place:
  - Overflow protection devices on tank systems to warn the operator to automatically shutdown transfer pumps when the tank reaches full capacity
  - Protective guards around tanks and piping to prevent vehicle or forklift damage
  - Clearly tagging or labeling all valves to reduce human error
  - Placement of spill kits at fueling areas and/or on vehicles.
- ✓ Stencil storm drain inlets within the facility boundary, by paint/stencil (or equivalent), to indicate whether they flow to an oil/water separator, directly to the sewer, or to a storm drain. Labels are not necessary for plumbing fixtures directly connected to the sanitary sewer.



## Spill Response

*See Spill Prevention and Control procedures sheet*

- ✓ Use absorbent materials on small spills and general cleaning rather than hosing down the area. Remove the absorbent materials promptly.
- ✓ Place a stockpile of spill cleanup materials where it will be readily accessible.
- ✓ Aboveground tank leak and spill control (not applicable to propane):
  - Check for external corrosion and structural failure
  - Check for spills and overfills due to operator error
  - Check for failure of piping system
  - Check for leaks or spills during pumping of liquids or gases from truck or rail car to a storage facility or vice versa
  - Visually inspect new tank or container installation for loose fittings, poor welding, and improper or poorly fitted gaskets
  - Inspect tank foundations, connections, coatings, and tank walls and piping system. Look for corrosion, leaks, cracks, scratches, and other physical damage that may weaken the tank or container system.

### OPTIONAL:

- Periodically, integrity testing should be conducted by a qualified professional.

---

## LIMITATIONS:

## REFERENCES:

*California Storm Water Best Management Practice Handbooks. Municipal Best Management Practice Handbook. Prepared by Camp Dresser & McKee, Larry Walker Associates, Uribe and Associates, Resources Planning Associates for Stormwater Quality Task Force. March 1993.*

King County Stormwater Pollution Control Manual. Best Management Practices for Businesses. 1995. King County Surface Water Management. July. On-line: <http://dnr.metrokc.gov/wlr/dss/spcm.htm>

Model Urban Runoff Program: A How-To Guide for Developing Urban Runoff Programs for Small Municipalities. Prepared by City of Monterey, City of Santa Cruz, California Coastal Commission, Monterey Bay National Marine Sanctuary, Association of Monterey Bay Area Governments, Woodward-Clyde, Central Coast Regional Water Quality Control Board. July. 1998.



## **LANDSCAPE MAINTENANCE**

**The model procedures described below focus on minimizing the discharge of pesticides and fertilizers, landscape waste, trash, debris, and other pollutants to the storm drain system and receiving waters. Landscape maintenance practices may involve one or more of the following activities:**

- 1. Mowing, Trimming/Weeding, and Planting**
- 2. Irrigation**
- 3. Fertilizer and Pesticide Management**
- 4. Managing Landscape Waste**
- 5. Erosion Control**

### **POLLUTION PREVENTION:**

Pollution prevention measures have been considered and incorporated in the procedures. Implementation of these measures may be more effective and reduce or eliminate the need to implement other more complicated or costly procedures. Possible pollution prevention measures for landscape maintenance include:

- Implement integrated pest management (IPM) program. IPM is a sustainable approach to managing pests by combining biological, cultural, physical, and chemical tools.
- Choose low water using flowers, trees, shrubs, and groundcover.
- Consider the selection of broadleaf evergreen trees to reduce leaf litter.
- Appropriate maintenance (i.e. properly timed fertilizing, weeding, pest control, and pruning) to preserve the landscapes water efficiency.
- Educate municipal staff on pollution prevention measures.

## MODEL PROCEDURES:

### 1. Mowing, Trimming/Weeding, and Planting

#### Mowing, Trimming/Weeding

- ✓ If feasible and practical, use mechanical methods of vegetation removal rather than applying herbicides. Use hand weeding where practical.
- ✓ When conducting mechanical or manual weed control, avoid loosening the soil, which could erode into streams or storm drains.
- ✓ If feasible and practical, use coarse textured mulches or geotextiles to suppress weed growth and reduce the use of herbicides.
- ✓ Do not blow or rake leaves, etc. into the street or place yard waste in gutters or on dirt shoulders. Sweep up any leaves, litter or residue in gutters or on street.
- ✓ Collect lawn and garden clippings, pruning waste, tree trimmings, and weeds. Chip if necessary, and compost or dispose of at a landfill (see waste management section of this procedure sheet).
- ✓ Place temporarily stockpiled material away from watercourses, and berm or cover stockpiles to prevent material releases to storm drains.

#### Planting

- ✓ Where feasible, retain and/or plant selected native vegetation whose features are determined to be beneficial. Native vegetation usually requires less maintenance (e.g., irrigation, fertilizer) than planting ornamental vegetation.
- ✓ When planting or replanting consider using low water use groundcovers.

#### OPTIONAL:

- Careful soil mixing and layering techniques using a topsoil mix or composted organic material can be used as an effective measure to reduce herbicide use and watering.

### 2. Irrigation

- ✓ Utilize water delivery rates that do not exceed the infiltration rate of the soil.
- ✓ Use timers appropriately or a drip system to prevent runoff and then only irrigate as much as is needed.
- ✓ Inspect irrigation system periodically to ensure that the right amount of water is being applied and that excessive runoff is not occurring. Minimize excess watering, and repair leaks in the irrigation system as needed.
- ✓ Where practical, use automatic timers to minimize runoff.
- ✓ Use popup sprinkler heads in areas with a lot of activity or where there is a chance the pipes may be broken. Consider the use of mechanisms that reduce water flow to sprinkler heads if broken.

- ✓ If re-claimed water is used for irrigation, ensure that there is no runoff from the landscaped area(s).
- ✓ If bailing of muddy water is required (e.g. when repairing a water line leak), do not put it in the storm drain; pour over landscaped areas.

OPTIONAL:

- Consider converting to an evapo-transpiration driven irrigation control system.

## 3. Fertilizer and Pesticide Management

### Usage

- ✓ Utilize a comprehensive management system that incorporates integrated pest management techniques.
- ✓ Follow all federal, state, and local laws and regulations governing the use, storage, and disposal of fertilizers and pesticides and training of applicators and pest control advisors.
- ✓ Educate and train employees on use of pesticides and in pesticide application techniques to prevent pollution.
- ✓ Pesticide application must be under the supervision of a California qualified pesticide applicator.
- ✓ When applicable use the least toxic pesticides that will do the job. Avoid use of copper-based pesticides if possible.
- ✓ Do not mix or prepare pesticides for application near storm drains.
- ✓ Prepare the minimum amount of pesticide needed for the job and use the lowest rate that will effectively control the pest.
- ✓ Employ techniques to minimize off-target application (e.g. spray drift) of pesticides, including consideration of alternative application techniques.
- ✓ Calibrate fertilizer and pesticide application equipment to avoid excessive application.
- ✓ Periodically test soils for determining proper fertilizer use.
- ✓ Sweep pavement and sidewalk if fertilizer is spilled on these surfaces before applying irrigation water.
- ✓ Inspect pesticide/fertilizer equipment and transportation vehicles frequently

OPTIONAL:

- Work fertilizers into the soil rather than dumping or broadcasting onto the surface.

- Use beneficial insects where possible to control pests (green lacewings, ladybugs, praying mantis, ground beetles, parasitic nematodes, trichogramma wasps, seedhead weevils, and spiders prey on detrimental pest species).
- Use slow release fertilizers whenever possible to minimize leaching.

## Scheduling

- ✓ Do not use pesticides if rain is expected within 24 hours.
- ✓ Apply pesticides only when wind speeds are low (less than 5 mph).

## Storage

- ✓ To minimize quantities of pesticides and fertilizers stored, only purchase what is needed for use in the near future.
- ✓ Implement storage requirements for pesticide products with guidance from the fire department and County Agricultural Commissioner. Provide secondary containment for pesticides.

## Disposal

- ✓ Purchase only the amount of pesticide that you can reasonably use in a given time period (month or year depending on the product).
- ✓ Triple rinse containers, and use rinse water as product. Dispose of unused pesticide as hazardous waste.
- ✓ Dispose of empty pesticide containers according to the instructions on the container label.

## 4. Managing Landscape Waste

- ✓ Compost leaves, sticks, or other collected vegetation or dispose of at a permitted landfill. Do not dispose of collected vegetation into waterways or storm drainage systems.
- ✓ Place temporarily stockpiled material away from watercourses and storm drain inlets, and berm or cover stockpiles to prevent material releases to the storm drain system.
- ✓ Reduce the use of high nitrogen fertilizers that produce excess growth requiring more frequent mowing or trimming.
- ✓ Inspection of drainage facilities should be conducted to detect illegal dumping of clippings/cuttings in or near these facilities. Materials found should be picked up and properly disposed of.
- ✓ Landscape wastes in and around storm drain inlets should be avoided by either using bagging equipment or manually picking the material up.

*Also see Waste Handling and Disposal procedure sheet*

## 5. Erosion Control

- ✓ Maintain vegetative cover on medians and embankments to prevent soil erosion. Apply mulch or leave clippings to serve as additional cover for soil stabilization and to reduce the velocity of storm water runoff.
- ✓ As medians are developed or re-developed, consider designing them so that they prevent runoff and erosion and promote better irrigation practices.
- ✓ Minimize the use of disking as a means of vegetation management because the practice may result in erodable barren soil.
- ✓ Confine excavated materials to pervious surfaces away from storm drain inlets, sidewalks, pavement, and ditches. Material must be covered if rain is expected.

---

### LIMITATIONS:

Alternative pest/weed controls may not be available, suitable, or effective in every case.

### REFERENCES:

*California Storm Water Best Management Practice Handbooks. Industrial/Commercial Best Management Practice Handbook. Prepared by Camp Dresser & McKee, Larry Walker Associates, Uribe and Associates, Resources Planning Associates for Stormwater Quality Task Force. July 1993.*

County of Orange. 2000. Public Facilities and Resources Department, Management Guidelines for the Use of Fertilizers and Pesticides. September.

King County Stormwater Pollution Control Manual. Best Management Practices for Businesses. 1995. King County Surface Water Management. July. On-line: <http://dnr.metrokc.gov/wlr/dss/spcm.htm>

Los Angeles County Stormwater Quality Model Programs. Public Agency Activities  
[http://ladpw.org/wmd/npdes/model\\_links.cfm](http://ladpw.org/wmd/npdes/model_links.cfm)

Model Urban Runoff Program: A How-To Guide for Developing Urban Runoff Programs for Small Municipalities. Prepared by City of Monterey, City of Santa Cruz, California Coastal Commission, Monterey Bay National Marine Sanctuary, Association of Monterey Bay Area Governments, Woodward-Clyde, Central Coast Regional Water Quality Control Board. July. 1998.

Santa Clara Valley Urban Runoff Pollution Prevention Program. 1997 Urban Runoff Management Plan. September 1997, updated October 2000.



**FF-6**

## **MATERIAL LOADING AND UNLOADING**

**The loading/unloading of materials usually takes place outside; therefore, materials spilled, leaked, or lost during loading/unloading have the potential to collect in the soil or on other surfaces and be carried away by runoff or when the area is cleaned. Additionally, rainfall may wash pollutants from machinery used to unload or move materials. Material loading and unloading involves the following activities:**

### **POLLUTION PREVENTION:**

Pollution prevention measures have been considered and incorporated in the procedures. Implementation of these measures may be more effective and reduce or eliminate the need to implement other more complicated or costly procedures. Possible pollution prevention measures for material loading and unloading include:

- Check loading and unloading equipment regularly for leaks.
- Cover loading docks.
- Educate municipal staff on pollution prevention measures.

### **MODEL PROCEDURES:**

#### **General Guidelines**

- ✓ Regularly clean work areas to remove materials such as debris, sandblasting material, etc.
- ✓ Design loading/unloading area to prevent stormwater runoff that would include grading or berming the area, and positioning roof downspouts so they direct stormwater away from loading/unloading areas.
- ✓ Use overhangs or door skirts that enclose the trailer.
- ✓ Park tank trucks or delivery vehicles so that spills or leaks can be contained.
- ✓ Avoid loading and exposing materials during rain events unless the loading dock is covered and protected from rain. A seal or door skirt between the trailer and the building may also prevent exposure to rain.
- ✓ Shipboard cooling and process water discharges should be directed to minimize contact with spent abrasives, paint, and other debris.

## Tank Truck Transfers

- ✓ The area where the transfer takes place should be paved. If the liquid is reactive with the asphalt, Portland cement should be used to pave the area.
- ✓ Transfer area should be designed to prevent runoff of stormwater from adjacent areas. Sloping the pad and using a berm around the uphill side of the transfer area should reduce runoff.
- ✓ Transfer area should be designed to prevent runoff of spilled liquids from the area. Sloping the area to a drain should prevent runoff. The drain should be connected to a dead-end sump. A positive control valve should be installed on the drain.

## Spill Control

*Also see Spill Prevention and Control procedures sheet*

- ✓ Contain leaks during transfer.
- ✓ Use drip pans under hoses.
- ✓ Have an emergency spill cleanup plan readily available.
- ✓ Place spill kits and materials next to or near each loading/unloading area.
- ✓ Use drip pans or comparable devices when transferring oils, solvents, and paints.

## Training

- ✓ Make sure forklift operators are properly trained.
- ✓ Train employees regarding spill containment and cleanup.
- ✓ Employees trained in spill containment and cleanup should be present during the loading/unloading.
- ✓ Use a written operations plan that describes procedures for loading and/or unloading.

## Inspection

*Also see Spill Prevention and Control procedures sheet*

- ✓ Check loading and unloading equipment regularly for leaks, including valves, pumps, flanges and connections.
- ✓ Inspect regularly for leaking valves, pipes, hoses, or soil chutes carrying either water or wastewater.
- ✓ Look for dust or fumes during loading or unloading operations.

---

## LIMITATIONS:

Space and time limitations may preclude all transfers from being performed indoors or under cover. It may not be possible to conduct transfers only during dry weather.



## REFERENCES:

*California Storm Water Best Management Practice Handbooks. Municipal Best Management Practice Handbook. Prepared by Camp Dresser & McKee, Larry Walker Associates, Uribe and Associates, Resources Planning Associates for Stormwater Quality Task Force. March 1993.*

Model Urban Runoff Program: A How-To Guide for Developing Urban Runoff Programs for Small Municipalities. Prepared by City of Monterey, City of Santa Cruz, California Coastal Commission, Monterey Bay National Marine Sanctuary, Association of Monterey Bay Area Governments, Woodward-Clyde, Central Coast Regional Water Quality Control Board. July. 1998.



**FF-7**

## **MATERIAL STORAGE, HANDLING, AND DISPOSAL**

**Accidental releases of materials from aboveground liquid storage tanks, drums, and dumpsters present the potential for contaminating stormwater with many different pollutants. Maintaining these areas may involve one or more of the following activities:**

- 1. Material Storage**
- 2. Chemical Material Handling and Disposal**
- 3. Hazardous Material Handling and Disposal**

### **POLLUTION PREVENTION:**

Pollution prevention measures have been considered and incorporated in the model procedures. Implementation of these measures may be more effective and reduce or eliminate the need to implement other more complicated or costly procedures. Possible pollution prevention measures for material storage, handling, and disposal include:

- Store material indoors, or covered if outdoors.
- Prevent storm water run-on.
- Educate municipal staff on pollution prevention measures.

### **MODEL PROCEDURES:**

#### **1. General Material Storage, Handling, and Disposal**

##### **Storage**

- ✓ Store materials indoors if possible. If stored outdoors, cover the storage area with a roof or with temporary cover during rain events. [*Note: the fire authority/department must be consulted for limitations on clearance of roof covers over containers used to store flammable materials*].
- ✓ Keep storage areas clean and dry. Conduct regular inspections so that leaks and spills are detected as soon as possible.
- ✓ Minimize stormwater run-on and runoff by covering, enclosing or providing secondary containment for the area.
- ✓ Keep outdoor storage areas in good condition (e.g. repair roofs, floors, etc. to limit releases to runoff).

- ✓ Drums stored in an area where unauthorized persons may gain access must be secured to prevent accidental spillage, pilferage, or any unauthorized use. Only personnel with proper training may handle hazardous waste. *See Waste Handling and Disposal Procedures*
- ✓ Wood products treated with chromated copper arsenate, ammonical copper zinc arsenate, creosote, or pentachlorophenol should be covered with tarps during rain events or stored indoors.
- ✓ Parking lots or other surfaces near bulk materials storage areas should be swept periodically to remove debris blown or washed from storage area.
- ✓ Train employees in proper storage measures.

## Secondary Containment

- ✓ Tanks should be bermed or surrounded by a secondary containment system such as dikes, liners, vaults, or double walled tanks.
- ✓ Keep liquids in a designated area on a paved impervious surface within a secondary containment.
- ✓ The area inside the berm should slope to a drain with a dead-end sump that is periodically pumped out.

## Inspection

- ✓ Inspect storage areas regularly for leaks or spills.
- ✓ Conduct routine inspections and check for external corrosion of material containers. Also check for structural failure, spills and overfills due to operator error, failure of piping system.
- ✓ Check for leaks or spills during pumping of liquids or gases from trucks to a storage facility or vice versa.
- ✓ Visually inspect new tank or container installations for loose fittings, poor welding, and improper or poorly fitted gaskets.
- ✓ Inspect tank foundations, connections, coatings, and tank walls and piping system. Look for corrosion, leaks, cracks, scratches, and other physical damage that may weaken the tank or container system.

## 2. General Chemical Material Handling and Disposal

### General Guidelines

*Types of chemical materials that may be stored:*

*Liquid chemicals  
Waste oils  
Solvents*

- ✓ Do not store chemicals, drums, or bagged materials directly on the ground. Place these items in secondary containers. Designate a secure chemical material storage area that is paved with Portland cement concrete, free of cracks and gaps, and impervious in order to contain leaks and spills.
- ✓ Containers should be placed in a designated area and covered.
- ✓ Design and maintain chemical storage areas that reduce exposure to storm water:
  - Store materials inside or under cover on paved surfaces
  - Use secondary containment (see section above)

*Types of chemical materials that may be stored: cont.*

*Petroleum products  
Paints  
Cleaners  
Pesticides  
Fertilizers  
Etc.*

## Spill Control

*See Spill Prevention and Control procedures sheet*

- ✓ Use covered dumpsters for waste product containers. Dumpsters shall be kept in good condition without corrosion or leaky seams. Garbage dumpsters shall be replaced if they are deteriorating to the point where leakage is occurring.
- ✓ Liquid materials should be stored in UL approved double walled tanks or surrounded by a curb or dike to provide the volume to contain 10 percent of the volume of all the containers or 110 percent of the volume of the largest container, whichever is greater.
- ✓ Try to keep chemicals in their original containers, and keep them well labeled.
- ✓ Keep secured lids on waste barrels and containers.
- ✓ Clean up spills immediately.
- ✓ Safeguards against accidental releases:
  - Overflow protection devices to warn operator or automatic shut down transfer pumps
  - Protection guards (bollards) around tanks and piping to prevent vehicle or forklift damage
- ✓ Clear tagging or labeling, and restricting access to valves to reduce human error.
- ✓ Employees trained in emergency spill cleanup procedures should be present when dangerous waste, liquid chemicals, or other wastes are delivered or transferred off-site.

## 3. General Hazardous Material Handling

### General Guidelines

*Also see Spill Control Section above and the Spill Prevention and Control procedures sheet*

- ✓ All hazardous waste must be labeled according to hazardous waste regulations. Consult the Orange Fire Department Hazardous Materials Specialist(s) for details.
- ✓ Store as few hazardous materials on-site as possible. Do not store any hazardous waste directly on the ground. Place these items in secondary containers. Designate a secure hazardous waste storage area that is paved with Portland cement concrete, free of cracks and gaps, and impervious in order to contain leaks and spills.
- ✓ Handle hazardous materials as infrequently as possible. Only properly trained personnel should handle hazardous waste.
- ✓ Storage of oil and hazardous materials must meet specific Federal and State standards including:
  - Spill Prevention Control and Countermeasure Plan
  - Secondary containment
  - Integrity and leak detection monitoring

- ✓ Never mix waste oil with fuel, antifreeze, or chlorinated solvents. Consult your hazardous waste hauler for details.
- ✓ Develop emergency preparedness plans.
- ✓ Employees should be familiar with the Hazardous Materials Disclosure Plan, if applicable.
- ✓ Employees trained in emergency spill cleanup procedures should be present when dangerous waste, liquid chemicals, or other wastes are delivered or transferred off-site.

## **Batteries**

- ✓ Store new batteries securely to avoid breakage and acid spills during earthquakes. Shelving should be secured to the wall.
- ✓ Store used batteries indoors and in plastic trays to contain potential leaks.
- ✓ Recycle old batteries.

---

## **LIMITATIONS:**

Storage sheds often must meet building and fire code requirements.

## **REFERENCES:**

*California Storm Water Best Management Practice Handbooks. Municipal Best Management Practice Handbook. Prepared by Camp Dresser & McKee, Larry Walker Associates, Uribe and Associates, Resources Planning Associates for Stormwater Quality Task Force. March 1993.*

King County Stormwater Pollution Control Manual. Best Management Practices for Businesses. 1995. King County Surface Water Management. July. On-line: <http://dnr.metrokc.gov/wlr/dss/spcm.htm>

Model Urban Runoff Program: A How-To Guide for Developing Urban Runoff Programs for Small Municipalities. Prepared by City of Monterey, City of Santa Cruz, California Coastal Commission, Monterey Bay National Marine Sanctuary, Association of Monterey Bay Area Governments, Woodward-Clyde, Central Coast Regional Water Quality Control Board. July. 1998.

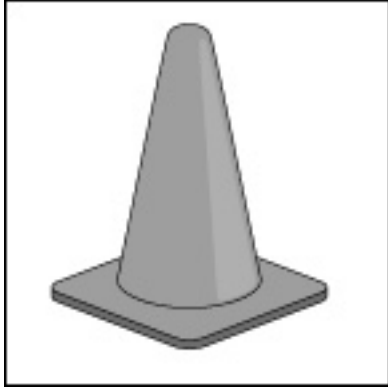

## MINOR CONSTRUCTION

**Minor construction activities can result in the use of materials or generation of waste that may contain toxic hydrocarbons or other organic compounds, suspended solids, heavy metals, abnormal pH, and oils and greases. Minor construction activities may involve one or more of the following:**

- 1. General Construction Activities**
- 2. Interim Material Storage**
- 3. Concrete Work**
- 4. Building Work**

### POLLUTION PREVENTION:

Pollution prevention measures have been considered and incorporated in the procedures. Implementation of these measures may be more effective and reduce or eliminate the need to implement other more complicated or costly procedures. Possible pollution prevention measures for minor construction include:

- Schedule activities during dry weather whenever possible.
- Use dry cleaning methods whenever possible.
- Educate municipal staff on pollution prevention measures.

### MODEL PROCEDURES:

#### 1. General Construction Activities

- ✓ Prevent debris from entering the storm drain.
- ✓ Do not wash materials into a storm drain or bury spilled dry material.
- ✓ Do not clean or rinse equipment into a street, gutter, or storm drain.
- ✓ Use a storm drain cover, filter fabric, or similarly effective runoff control mechanism if dust, grit, wash water, or other pollutants may escape the work area and enter a storm drain inlet. This is particularly necessary on rainy days. The containment device(s) must be in place at the beginning of the work day, and accumulated dirty runoff and solids must be

*See Waste Handling and Disposal procedure sheet*

collected and disposed of before removing the containment device(s) at the end of the work day.

- ✓ Clean the storm drain inlets in the immediate vicinity of the construction activity after it is completed.
- ✓ If a spill occurs on dirt, excavate and remove the contaminated (stained) soil.
- ✓ Clean up spills and leaks immediately using dry methods, whenever possible.
- ✓ Designate an area for clean up and proper disposal of excess materials.
- ✓ Sweep up dry materials and residue from cleaning operations. Avoid using water to clean up.
- ✓ Use soil erosion control techniques if bare ground is temporarily exposed.
- ✓ Promptly clean up trash, debris, and litter from job sites and dispose properly.
- ✓ Inspect vehicles and equipment used at the construction site regularly for leaks.
- ✓ Train employees and subcontractors in proper waste management.

## 2. Interim Material Storage

- ✓ Properly store and cover materials that are normally used during minor construction such as paints, solvents, equipment, fuel, asphalt/concrete materials, sand, etc.
- ✓ Properly store and dispose of wastes generated from the activity.
- ✓ Store dry and wet materials under cover, protected from rainfall and runoff and away from storm drain inlets. After job is complete, remove temporary stockpiles (asphalt materials, sand, etc.) and other materials as soon as possible.
- ✓ Store products in labeled containers and with covers or lids.
- ✓ Keep paved areas adjacent to stockpiles and earthwork sites free from loose sediment and tracked materials.
- ✓ Place stockpiled materials away from storm drain inlets, drainage paths, and natural waterways and provide cover to protect from runoff/runoff if feasible.
- ✓ Control stockpiled materials if windy or rainy weather is predicted (e.g. tarps, berming, sandbags, etc.).
- ✓ Prevent storm water from eroding loose soil and stockpiles.
- ✓ Inspect stockpiles regularly and after significant rain events.

### 3. Concrete Work

- ✓ Take measures to protect nearby storm drain inlets prior to breaking up asphalt or concrete (e.g. place hay bales or sand/gravel bags around inlets). Clean up waste material using dry methods.
- ✓ When making saw cuts in pavement, use as little water as possible. Cover each storm drain inlet completely with filter fabric during the sawing operation and contain the slurry by placing straw bales, sandbags, or gravel dams around the inlets. Vacuum saw cuttings and water from the pavement or gutter and remove from site.
- ✓ Apply concrete, asphalt, and seal coat during dry weather to prevent contamination from contacting stormwater runoff.
- ✓ Protect applications of fresh concrete from rainfall and runoff until the material has dried.
- ✓ Do not allow excess concrete to be dumped on-site, except in designated areas and promptly remove when concrete has dried.
- ✓ Tarps should be placed under concrete pumper trucks and the rear of trucks while concrete is being delivered or transferred from one area to another.
- ✓ Wash concrete trucks and concrete pumper trucks and trailers off site or in designated areas on site, such that there is no discharge of concrete wash water into storm drains, open ditches, streets, catch basins, or other stormwater conveyance structures.
- ✓ For on-site washout:
  - Locate washout area at least 50 feet from storm drains, open ditches, or water bodies. Do not allow runoff from this area by constructing a temporary pit or bermed area large enough for liquid and solid waste.
  - Wash out wastes into the temporary pit where the concrete can set, be broken up, and then disposed of properly.
  - Whenever possible, recycle washout by pumping back into mixers for reuse.
  - Never dispose of washout into the street, storm drains, drainage ditches, or creeks.
- ✓ When washing concrete to remove fine particles and expose the aggregate, contain the wash water for proper disposal. Do not allow water to enter storm drain inlets.
- ✓ Do not wash sweepings from exposed aggregate concrete into the street or storm drain. Collect and return sweepings to aggregate base stock pile, or dispose in the trash
- ✓ Return left-over materials to the transit mixer. Dispose excess concrete, grout, and mortar in the trash.



## 4. Building Work

### General Guidelines

- ✓ Use ground or drop cloths underneath outdoor painting, scraping, and sandblasting work, and properly dispose of collected material daily.
- ✓ Do not dump any toxic substance or liquid waste on the pavement, the ground, or toward a storm drain.
- ✓ Use a ground cloth or oversized tub for activities such as paint mixing and tool cleaning.
- ✓ Clean paint brushes and tools covered with water-based paints in sinks connected to sanitary sewers. Brushes and tools covered with non-water-based paints, finishes, or other materials must be cleaned in a manner that enables collection of used solvents (e.g., paint thinner, turpentine, etc.) for recycling or proper disposal.
- ✓ If a spill occurs on dirt, excavate and remove the contaminated (stained) soil.

### Building Demolition

- ✓ Spray water throughout the site to help control wind-blowing of fine materials such as soil, concrete dust, paint chips, and metal chips. The amount of water must be controlled so that runoff from the site does not occur; yet dust control is accomplished.
- ✓ Oils must never be used for dust control.
- ✓ Place filter fabric or a similarly effective device at nearby storm drain inlets to prevent particles and solids from entering the storm drainage system. Filters should be placed at the beginning of the workday and the accumulated materials collected and disposed properly before removing them at the end of the workday
- ✓ Dry sweep surrounding street gutters, sidewalks, driveways, and other paved surfaces at the end of each workday to collect and properly dispose of loose debris and garbage; do not hose down the area to a storm drain.
- ✓ Use permanent soil erosion control techniques if a building cleared from an area is not to be replaced.

---

### LIMITATIONS:

This procedure sheet is for minor construction only; the State's General Construction Activity Storm Water permit has more requirements for larger projects. Be certain that actions to help stormwater quality are consistent with Cal- and Fed-OSHA and air quality regulations.

## REFERENCES:

*California Storm Water Best Management Practice Handbooks. Municipal Best Management Practice Handbook. Prepared by Camp Dresser & McKee, Larry Walker Associates, Uribe and Associates, Resources Planning Associates for Stormwater Quality Task Force. March 1993.*

King County Stormwater Pollution Control Manual. Best Management Practices for Businesses. 1995. King County Surface Water Management. July. On-line: <http://dnr.metrokc.gov/wlr/dss/spcm.htm>

The Stormwater Managers Resource Center (<http://www.stormwatercenter.net/>)

Model Urban Runoff Program: A How-To Guide for Developing Urban Runoff Programs for Small Municipalities. Prepared by City of Monterey, City of Santa Cruz, California Coastal Commission, Monterey Bay National Marine Sanctuary, Association of Monterey Bay Area Governments, Woodward-Clyde, Central Coast Regional Water Quality Control Board. July. 1998.



**FF-9**

## **PARKING LOT MAINTENANCE**

**Litter accumulation in parking lots can contribute suspended solids to stormwater runoff; runoff from parking lots may also contain hydrocarbons, oil and grease, and heavy metals to stormwater. Maintaining these areas may involve one or more of the following activities:**

- 1. Sweeping and Cleaning**
- 2. Repair**

### **POLLUTION PREVENTION:**

Pollution prevention measures have been considered and incorporated in the procedures. Implementation of these measures may be more effective and reduce or eliminate the need to implement other more complicated or costly procedures. Possible pollution prevention measures for parking lot maintenance include:

- Keep accurate maintenance logs to evaluate materials removed and improvements made.
- When repairing parking lots, consider making retrofits that will reduce storm runoff quantities (i.e. permeable surface, directing surface flows to landscaped areas, etc.)
- Educate municipal staff on pollution prevention measures.
- Educate others about storm water pollution prevention.

### **MODEL PROCEDURES:**

#### **1. Sweeping and Cleaning**

- ✓ Sweep/vacuum all parking lots at least once before the onset of the wet season.
- ✓ When cleaning with water use the procedures below:
  - Block the storm drain or contain runoff.
  - Wash water should be collected and disposed of properly. If wash water does not contain soap or other cleaning agents the water may be discharged to a pervious surface (dirt or landscaped area).

- ✓ Dispose of parking lot sweeping debris and dirt at a landfill.
- ✓ When cleaning heavy oily deposits:
  - Clean oily spots with absorbent materials
  - Do not allow discharges to the storm drain
  - Collect wash water and dispose of properly.
- ✓ Appropriately dispose of spilled materials and absorbents.
- ✓ If cleaning agents are used, select biodegradable products.

OPTIONAL:

- If necessary, establish more frequent sweeping schedule based on usage and field observations of waste accumulation.

## Litter Control

- ✓ Enforce anti-litter laws.
- ✓ Provide an adequate number of litter receptacles.
- ✓ Clean out frequently and/or cover litter receptacles to prevent spillage.
- ✓ Sweep/vacuum all parking lots at least once before the onset of the wet season.

OPTIONAL:

- Post "No Littering" signs.

## 3. Surface Repair

- ✓ Pre-heat, transfer or load hot bituminous material away from storm drain inlets.
- ✓ Apply concrete, asphalt, and seal coat during dry weather to prevent contamination from contacting stormwater runoff.
- ✓ Cover and seal nearby storm drain inlets (with waterproof material or mesh) and manholes before applying seal coat, slurry seal, etc. Leave covers in place until job is complete and until all water from emulsified oil sealants has drained or evaporated. Clean any debris from these covered maintenance holes and drains for proper disposal.
- ✓ Use only as much water as necessary for dust control, to avoid runoff.
- ✓ Catch drips from paving equipment that is not in use with pans or absorbent material placed under the machines. Dispose of collected material and absorbents properly.

## 4. Control Spills

*See Spill Prevention and Control procedure sheet*

- ✓ If a spill occurs on dirt, excavate and remove the contaminated (stained) dirt.
- ✓ Store spill response materials at a central location and keep maintenance vehicles adequately supplied.
- ✓ Appropriately dispose of spilled materials and absorbents.

### LIMITATIONS:

Limitations related to sweeping activities at large parking facilities may include current sweeper technology to remove oil and grease.

### REFERENCES:

*California Storm Water Best Management Practice Handbooks. Municipal Best Management Practice Handbook. Prepared by Camp Dresser & McKee, Larry Walker Associates, Uribe and Associates, Resources Planning Associates for Stormwater Quality Task Force. March 1993.*

The Stormwater Managers Resource Center (<http://www.stormwatercenter.net/>)

Model Urban Runoff Program: A How-To Guide for Developing Urban Runoff Programs for Small Municipalities. Prepared by City of Monterey, City of Santa Cruz, California Coastal Commission, Monterey Bay National Marine Sanctuary, Association of Monterey Bay Area Governments, Woodward-Clyde, Central Coast Regional Water Quality Control Board. July. 1998.

Oregon Association of Clean Water Agencies. Oregon Municipal Stormwater Toolbox for Maintenance Practices. June 1998.

Santa Clara Valley Urban Runoff Pollution Prevention Program. 1997 Urban Runoff Management Plan. September 1997, updated October 2000.

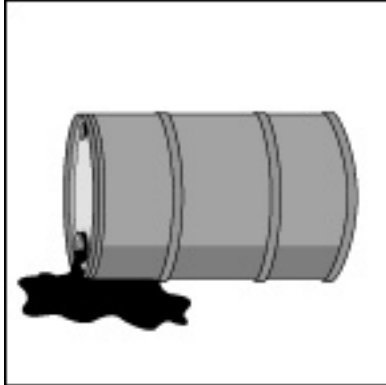

## **SPILL PREVENTION AND CONTROL**

**Preparation for accidental or illegal spills, with proper training and reporting systems implemented, can minimize the discharge of pollutants to the environment. Specific spill prevention and response activities may involve one or more of the following activities:**

- 1. Preparation/Prevention**
- 2. Spill Response**
- 3. Reporting**
- 4. Training**

### **MODEL PROCEDURES:**

#### **1. Preparation/Prevention**

- ✓ Adopt the Orange County Hazardous Materials Area Plan or equivalent plan which includes a set of planned responses to hazardous materials emergencies, addressing chain-of-command, public agency participation and allocation of authority.
- ✓ Place a stockpile of spill cleanup materials where it will be readily accessible.
- ✓ Develop procedures to prevent/mitigate spills to storm drain systems. Develop and standardize reporting procedures, containment, storage, and disposal activities, documentation, and follow-up procedures.
- ✓ Identify key spill response personnel.

## 2. Spill Response

- ✓ Clean up leaks and spills immediately.
- ✓ On paved surfaces, clean up spills with as little water as possible. Use a rag for small spills, a damp mop for general cleanup, and absorbent material for larger spills. If the spilled material is hazardous, then the used cleanup materials are also hazardous and must be sent to a certified laundry (rags) or disposed of as hazardous waste.
- ✓ Never hose down or bury dry material spills. Sweep up the material and dispose of properly.
- ✓ Use absorbent materials on small spills rather than hosing down the spill. Remove the adsorbent materials promptly and dispose of properly.
- ✓ For larger spills, a private spill cleanup company or Hazmat team may be necessary.

### OPTIONAL:

- If illegal dumping is observed at the facility, post "No Dumping" signs with a phone number for reporting dumping and disposal.

## 3. Reporting

- ✓ Report spills or problems to a city Authorized Inspector

## 4. Training

- ✓ Educate employees about spill prevention and cleanup.

---

### LIMITATIONS:

For hazardous spills, a private spill cleanup company or Hazmat team may be necessary. Proper training is crucial to reducing the frequency, severity, and impacts of leaks and spills.

### REFERENCES:

*California Storm Water Best Management Practice Handbooks. Municipal Best Management Practice Handbook. Prepared by Camp Dresser & McKee, Larry Walker Associates, Uribe and Associates, Resources Planning Associates for Stormwater Quality Task Force. March 1993.*

The Stormwater Mangers Resource Center (<http://www.stormwatercenter.net/>)

Model Urban Runoff Program: A How-To Guide for Developing Urban Runoff Programs for Small Municipalities. Prepared by City of Monterey, City of Santa Cruz, California Coastal Commission, Monterey Bay National Marine Sanctuary, Association of Monterey Bay Area Governments, Woodward-Clyde, Central Coast Regional Water Quality Control Board. July. 1998.



## VEHICLE AND EQUIPMENT CLEANING

**Vehicle and equipment cleaning activities can contribute toxic hydrocarbons and other organic compounds, oils and greases, nutrients, heavy metals, and suspended solids to stormwater runoff. Use of the procedures outlined below can prevent or reduce the discharge of pollutants to stormwater during vehicle and equipment cleaning.**

- 1. Inspection and Cleaning of Stormwater Conveyance Structures**
- 2. Controlling Illicit Connections and Discharges**
- 3. Controlling Illegal Dumping**

### **POLLUTION PREVENTION:**

Pollution prevention measures have been considered and incorporated in the procedures. Implementation of these measures may be more effective and reduce or eliminate the need to implement other more complicated or costly procedures. Possible pollution prevention measures for vehicle and equipment cleaning include:

- Use outside service agencies to clean vehicles and equipment.
- Educate municipal staff on pollution prevention measures.

### **MODEL PROCEDURES:**

If the facility washes or steam cleans a large number of vehicles or pieces of equipment, consider contracting out this work to a commercial business. These businesses are better equipped to handle and dispose of the wash waters properly. Contracting out this work can also be economical by eliminating the need for a separate washing/cleaning operation at your facility.

If washing/cleaning must occur on-site follow these procedures:

- ✓ Use designated wash areas to prevent contact with stormwater and bermed to contain wash water.
- ✓ Designated wash areas must be well marked with signs indicating where and how washing must be done.
- ✓ Water may be discharged to the sanitary sewer after flowing through a clarifier. If the above conditions are not met, other pre-treatment may be required.



→ *Note: Permission must be obtained for any discharge of wash water to the sanitary sewer from the local sewerage agency.*

- ✓ Do not permit steam cleaning or engine degreasing at the wash out area.
- ✓ Washing operations should be conducted in a designated wash area having the following characteristics:
  - Paved with Portland cement concrete
  - Covered or bermed to prevent contact with storm water
  - Sloped for wash water collection
  - Connected to the sanitary sewer – upon approval.
  - Clearly designated

OPTIONAL:

- Consider filtering and recycling wash water.
- Equip wash areas with oil/water separators.

---

## LIMITATIONS

Steam cleaning can generate significant pollutant concentrations requiring permitting, monitoring, pretreatment, and inspections. The measures outlined in this procedure sheet are insufficient to address all the environmental impacts and compliance issues related to steam cleaning.

## REFERENCES:

*California Storm Water Best Management Practice Handbooks. Municipal Best Management Practice Handbook. Prepared by Camp Dresser & McKee, Larry Walker Associates, Uribe and Associates, Resources Planning Associates for Stormwater Quality Task Force. March 1993.*

The Stormwater Mangers Resource Center (<http://www.stormwatercenter.net/>)

Model Urban Runoff Program: A How-To Guide for Developing Urban Runoff Programs for Small Municipalities. Prepared by City of Monterey, City of Santa Cruz, California Coastal Commission, Monterey Bay National Marine Sanctuary, Association of Monterey Bay Area Governments, Woodward-Clyde, Central Coast Regional Water Quality Control Board. July. 1998.



## VEHICLE AND EQUIPMENT STORAGE

Stormwater runoff from vehicle and equipment storage areas can be contaminated with toxic hydrocarbons and other organic compounds, oils and greases, heavy metals, nutrients, and suspended solids. Activities associated with vehicle and equipment storage may involve one or more of the following:

1. Storing Vehicles and Equipment
2. Wrecked Vehicle Storage
3. Cleaning Storage Areas

Related vehicle maintenance activities are covered under the following program headings in this manual: “Vehicle and Equipment Cleaning”, “Equipment Maintenance and Repair”, and “Vehicle Fueling”.

### POLLUTION PREVENTION:

Pollution prevention measures have been considered and incorporated in the procedures. Implementation of these measures may be more effective and reduce or eliminate the need to implement other more complicated or costly procedures. Possible pollution prevention measures for vehicle and equipment storage include:

- Use outside service agencies to clean vehicle storage areas and collect water for off-site disposal.
- Educate municipal staff on pollution prevention measures.

### MODEL PROCEDURES:

#### 1. Storing Vehicles and Equipment

##### General Guidelines

- ✓ Place drip pans or absorbent materials under vehicles and heavy equipment when not in use.
- ✓ Inspect the storage yard for filling drip pans and other problems (leaking equipment) regularly.
- ✓ Train employees on procedures for storage and inspection items.

## Batteries

- ✓ Store batteries that have been dropped or are cracked in a secondary container even if it appears that the acid has already drained.

## 2. Wrecked Vehicle Storage

- ✓ As the vehicles arrive, place drip pans under them immediately, even if the fluids have leaked out before the car arrives.
- ✓ Drain all fluids from wrecked vehicles and "part" cars. Also drain engines, transmission, and other used parts.
- ✓ Promptly transfer used fluids to the proper container; do not leave full drip pans or other open containers lying around.
- ✓ Do not store vehicles near storm drain inlets.
- ✓ Comply with all applicable State and Federal regulations regarding storage, handling, and transport of petroleum products.

## 3. Cleaning Vehicle Storage Areas

- ✓ Dry sweep parking lots, storage areas, and driveways at least once per month to collect dirt, waste, and debris; do not hose down the area to a storm drain.
- ✓ Considering using an outside service to clean vehicle storage areas and collect water for off-site disposal.

---

### LIMITATIONS:

It may not be possible to contain and clean up spills from vehicles/equipment brought on-site after working hours.

### REFERENCES:

*California Storm Water Best Management Practice Handbooks. Municipal Best Management Practice Handbook. Prepared by Camp Dresser & McKee, Larry Walker Associates, Uribe and Associates, Resources Planning Associates for Stormwater Quality Task Force. March 1993.*

King County Stormwater Pollution Control Manual. Best Management Practices for Businesses. 1995. King County Surface Water Management. July. On-line: <http://dnr.metrokc.gov/wlr/dss/spcm.htm>

Los Angeles County Stormwater Quality Model Programs. Public Agency Activities  
[http://ladpw.org/wmd/npdes/model\\_links.cfm](http://ladpw.org/wmd/npdes/model_links.cfm)

Model Urban Runoff Program: A How-To Guide for Developing Urban Runoff Programs for Small Municipalities. Prepared by City of Monterey, City of Santa Cruz, California Coastal Commission, Monterey Bay National Marine Sanctuary, Association of Monterey Bay Area Governments, Woodward-Clyde, Central Coast Regional Water Quality Control Board. July. 1998.



**FF-13**

## **WASTE HANDLING AND DISPOSAL**

**Improper storage of solid wastes can allow toxic compounds, oils and greases, heavy metals, nutrients, suspended solids, and other pollutants to enter stormwater runoff. The discharge of pollutants to stormwater from waste handling and disposal can be prevented and reduced by tracking waste generation, storage, and disposal; reducing waste generation and disposal through source reduction and recycling; and preventing run-on and runoff. Proper waste handling and disposal activities include the following:**

- 1. Litter Control**
- 2. Waste Collection**
- 3. Spill/Leak Control**
- 4. Run-on/Runoff Prevention**

### **POLLUTION PREVENTION:**

Pollution prevention measures have been considered and incorporated in the procedures. Implementation of these measures may be more effective and reduce or eliminate the need to implement other more complicated or costly procedures. Possible pollution prevention measures for waste handling and disposal include:

- Reuse products when possible.
- Recycle leftover products that are recyclable.
- Educate municipal staff on pollution prevention measures.

### **MODEL PROCEDURES:**

#### **1. Litter Control**

##### **General Guidelines**

- ✓ Enforce anti-litter laws.
- ✓ Provide a sufficient number of litter receptacles at each fixed facility.
- ✓ Clean out and cover litter receptacles frequently to prevent spillage.

##### **OPTIONAL:**

- Post "No Littering" signs.

- Place trash receptacles at transit stops and maintain as necessary

## 2. Waste Collection

### General Guidelines

- ✓ Keep waste collection areas clean.
- ✓ Regularly inspect solid waste containers for structural damage. Repair or replace damaged containers as necessary.
- ✓ Secure solid waste containers; containers should be closed tightly when not in use.
- ✓ Do not fill waste containers with washout water or any other liquid.
- ✓ Ensure that only appropriate solid wastes are added to the solid waste container. Certain wastes such as hazardous wastes, appliances, fluorescent lamps, pesticides, etc. may not be disposed of in solid waste containers (see chemical/ hazardous waste collection section below).
- ✓ Do not mix liquid wastes; this can cause chemical reactions, make recycling impossible, and complicate disposal.

### Good Housekeeping

→ *Note: Permission must be obtained for any discharge of wash water to the sanitary sewer from the local sewerage agency.*

- ✓ Use the entire product before disposing of the container.
- ✓ The waste management area should be kept clean by sweeping and cleaning up spills immediately.
- ✓ When cleaning around dumpster areas use dry methods when possible (e.g. sweeping, use of absorbents). If water must be used after sweeping/using absorbents, collect water and discharge to landscaped area or discharge through grease interceptor to the sewer if permitted to do so.

### Chemical/Hazardous Waste Management

- ✓ All hazardous waste must be labeled according to hazardous waste regulations. Consult Fire Department or local hazardous waste agency for details.
- ✓ Educate/train employees and subcontractors in proper hazardous waste handling management practices.
- ✓ Handle hazardous materials as infrequently as possible. Only properly trained personnel should handle hazardous waste.
- ✓ Select designated hazardous waste collection areas on-site and make sure that hazardous waste is collected, removed, and disposed of only at these authorized disposal areas.
- ✓ Hazardous wastes may only be stored for 90 days or less, unless the facility obtains a permit.
- ✓ Hazardous materials and wastes should be stored in covered containers and protected from vandalism.
- ✓ Place hazardous waste containers in secondary containment.

## Waste Reduction/ Recycling

✓ Stencil storm drains on the facility's property

✓ Recycle materials whenever possible.

### OPTIONAL:

- Reduce the amount of waste generated by using source controls such as:
  - Production planning and sequencing
  - Process or equipment modification
  - Raw material substitution or elimination
  - Loss prevention and housekeeping
  - Waste segregation and separation
  - Close loop recycling
- Establish a material tracking system to increase awareness about material usage. This may reduce spills and minimize contamination, thus reducing the amount of waste produced.

## 3. Spill/Leak Control:

*Also see Spill Prevention and Control procedure sheet*

✓ Clean up spills immediately.

✓ Spill cleanup materials should be placed where they are easily accessible.

✓ Minimize spillage/leaking from solid waste containers. For larger solid waste containers (especially compactors) that utilize a hydraulic fluid pump system, regularly inspect and replace faulty pumps or hoses to minimize the potential of releases and spills.

✓ Check waste management areas for leaking containers or spills.

✓ Leaking equipment including valves, lines, seals, or pumps should be repaired promptly.

✓ Transfer waste from damaged containers into safe containers.

✓ Vehicles transporting waste should have spill prevention equipment that can prevent spills during transport. The spill prevention equipment includes:

- Vehicles equipped with baffles for liquid waste
- Trucks with sealed gates and spill guards for solid waste

✓ Special care should be taken when loading or unloading wastes; *See Loading and Unloading procedure sheet.*

## 4. Run-on/Runoff Prevention

- ✓ Prevent stormwater run-on from entering waste management areas by enclosing the area or building a berm around the area.
- ✓ Prevent the waste materials from directly contacting rain.
- ✓ Cover waste areas with a permanent roof if feasible. If not feasible, cover waste piles with temporary covering material such as reinforced tarpaulin, polyethylene, polyurethane, polypropylene or hypalon.
- ✓ If possible, move the activity indoors; ensuring first that all safety concerns such as fire hazard and ventilation are addressed.
- ✓ Dumpsters should be covered to prevent rain from washing waste out of holes or cracks in the bottom of the dumpster.

### OPTIONAL:

- Minimize the runoff of stormwater for land application by:
  - Choosing a site where slopes are under 6%, the soil is permeable, there is a low water table, it is located away from wetlands or marshes, there is a closed drainage system.
  - Avoiding application of waste to the site when it is raining or when the ground is saturated with water.
  - Growing vegetation on land disposal areas to stabilize soils and reduce the volume of surface water runoff from the site.
  - Maintaining adequate barriers between the land application site and the receiving waters. Planted strips are particularly good.
  - Using erosion control techniques such as mulching and matting, filter fences, straw bales, diversion terracing, and sediment basins.
  - Performing routine maintenance to ensure the erosion control or site stabilization measures are working.

---

### LIMITATIONS:

Hazardous waste cannot be re-used or recycled; it must be disposed of by a licensed hazardous waste hauler.

### REFERENCES:

*Bay Area Stormwater Management Agencies Association. 1996. Pollution From Surface Cleaning.*

*California Storm Water Best Management Practice Handbooks. Municipal Best Management Practice Handbook. Prepared by Camp Dresser & McKee, Larry Walker Associates, Uribe and Associates, Resources Planning Associates for Stormwater Quality Task Force. March 1993.*

# FF-13

Harvard University. 2002. Solid Waste Container Best Management Practices – Fact Sheet On-Line Resources – Environmental Health and Safety.

Model Urban Runoff Program: A How-To Guide for Developing Urban Runoff Programs for Small Municipalities. Prepared by City of Monterey, City of Santa Cruz, California Coastal Commission, Monterey Bay National Marine Sanctuary, Association of Monterey Bay Area Governments, Woodward-Clyde, Central Coast Regional Water Quality Control Board. July. 1998.



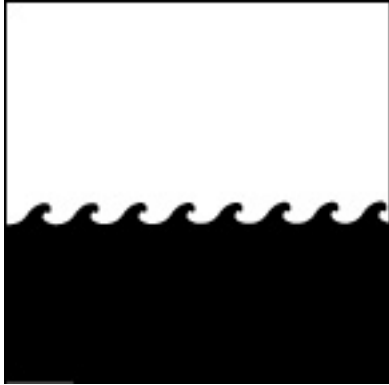

## **LAKE MANAGEMENT**

**The model procedures described below focus on minimizing the discharge of pesticides and fertilizers, landscape waste, trash, debris, sediments and other pollutants while maintaining ponds and lakes. Lake management practices may involve the following activities:**

- 1. Fertilizer and Pesticide Management**
- 2. Mowing, Trimming/Weeding, and Planting**
- 3. Managing Landscape Waste**
- 4. Controlling Litter**
- 5. Erosion Control**
- 6. Controlling Illegal Dumping**
- 7. Bacteria Control**
- 8. Monitoring**

### **POLLUTION PREVENTION:**

Pollution prevention measures have been considered and incorporated in the model procedures. Implementation of these measures may be more effective and reduce or eliminate the need to implement other more complicated or costly procedures. Possible pollution prevention measures for lake management include:

- Implementation of an integrated pest management (IPM) program. IPM is a sustainable approach to managing pests by combining biological, cultural, physical, and chemical tools.
- Educate municipal staff on pollution prevention measures.

## MODEL PROCEDURES:

### 1. Fertilizer and Pesticide Management

#### Usage

- ✓ Utilize a comprehensive management system that incorporates integrated pest management techniques.
- ✓ Follow all federal, state, and local laws and regulations governing the use, storage, and disposal of fertilizers and pesticides and training of applicators and pest control advisors.
- ✓ Educate and train employees on use of pesticides and pesticide application techniques to prevent pollution.
- ✓ Pesticide application must be under the supervision of a qualified and properly licensed or certified pesticide applicator.
- ✓ When applicable use the least toxic pesticides that will do the job. Avoid use of copper-based pesticides if possible.
- ✓ Do not mix or prepare pesticides for application near storm drains.
- ✓ Prepare the minimum amount of pesticide needed for the job and use the lowest rate that will effectively control the pest.
- ✓ Employ techniques to minimize off-target application (e.g. spray drift) of pesticides, including consideration of alternative application techniques.
- ✓ Calibrate fertilizer and pesticide application equipment to avoid excessive application.
- ✓ Periodically test soils for determining proper fertilizer use.
- ✓ Sweep pavement and sidewalk if fertilizer is spilled on these surfaces before applying irrigation water.
- ✓ Inspect pesticide/fertilizer equipment and transportation vehicles daily.
- ✓ Refer to permit "Monitoring and Reporting Program No.2001-160 for Discharges of Aquatic Pesticides to Waters of the United States" if lake discharges to Waters of the United States.

#### OPTIONAL:

- Use beneficial insects where possible to control pests (green lacewings, ladybugs, praying mantis, ground beetles, parasitic nematodes, trichogramma wasps, seedhead weevils, and spiders prey on detrimental pest species).
- Use slow release fertilizers whenever possible to minimize leaching.

## **Scheduling**

- ✓ Do not use pesticides if rain is expected within 24 hours.
- ✓ Apply pesticides only when wind speeds are low (less than 5 mph).

## **Disposal**

- ✓ Purchase only the amount of pesticide that you can reasonably use in a given time period (month or year depending on the product).
- ✓ Triple rinse containers, and use rinse water as product. Dispose of unused pesticide as hazardous waste.
- ✓ Dispose of empty pesticide containers according to the instructions on the container label.

## **2. Mowing, Trimming/Weeding, and Planting**

### **Mowing, Trimming/Weeding**

- ✓ Whenever possible, use mechanical methods of vegetation removal rather than applying herbicides. Use hand weeding where practical.
- ✓ When conducting mechanical or manual weed control, avoid loosening the soil, which could erode into the lake.
- ✓ Use coarse textured mulches or geotextiles to suppress weed growth and reduce the use of herbicides.
- ✓ Do not blow or rake leaves, etc. into a lake or place yard waste in lake.
- ✓ Collect lawn and garden clippings, pruning waste, tree trimmings, and weeds. Chip if necessary, and compost or dispose of at a landfill (see waste management section of this procedure sheet).
- ✓ Place temporarily stockpiled material away from lakes, and berm or cover stockpiles to prevent material releases to storm drains.

### **Planting**

- ✓ Where feasible, retain and/or plant selected native vegetation whose features are determined to be beneficial. Native vegetation usually requires less maintenance (e.g., irrigation, fertilizer) than planting new vegetation.
- ✓ When planting or replanting consider using low water use groundcovers.
- ✓ Create a grassy berm to reduce run-on and run-off when possible

#### OPTIONAL:

- Careful soil mixing and layering techniques using a topsoil mix or composted organic material can be used as an effective measure to reduce herbicide use and watering.

## 3. Managing Landscape Waste

*Also see Waste Handling and Disposal procedure sheet*

- ✓ Compost leaves, sticks, or other collected vegetation or dispose of at a permitted landfill. Do not dispose of collected vegetation into lakes.
- ✓ Place temporarily stockpiled material away from lakes. Berm or cover stockpiles to prevent material releases to a lake.
- ✓ Reduce the use of high nitrogen fertilizers that produce excess growth requiring more frequent mowing or trimming, and may contribute to excessive algae growth.
- ✓ Inspection should be conducted to detect illegal dumping of clippings/cuttings in or near a lake. Materials found should be picked up and properly disposed of.
- ✓ Landscape wastes in and around lakes should be avoided by either using bagging equipment or by manually picking up the material.

### Training/Education/Outreach

- ✓ Train municipal staff to recognize and report illegal dumping into lakes.
- ✓ Encourage public reporting of illegal dumping by advertising the City's 24-hour water pollution problem reporting hotline (714) 538-1961 as well as the countywide 24 hour hotline at (877) 89-SPILL.

#### OPTIONAL:

- Educate the public with public education materials such as a hotline and/or door hanger (door hangers are placed on the front doors in neighborhoods where illegal dumping has occurred to inform the reader why illegal dumping is a problem, and that illegal dumping carries a significant financial penalty).
- Educate the public through volunteer water quality monitoring programs. Volunteers can be trained to notice and report the presence and suspected source of an observed pollutant to the appropriate public agency.

## 4. Controlling Litter

### Enforce anti-litter laws.

*Also see Solid Waste Handling procedure sheet*

- ✓ Provide litter receptacles near lakes.
- ✓ Cover litter receptacles and clean out frequently to prevent leaking/spillage or overflow.

#### OPTIONAL:

- Post "No Littering" signs.

## 5. Controlling Erosion

- ✓ Maintain vegetative cover on banks to prevent soil erosion. Apply mulch or leave clippings to serve as additional cover for soil stabilization and to reduce the velocity of storm water runoff.
- ✓ Areas should be designed (sloped) to prevent runoff and erosion and to promote better irrigation practices.
- ✓ Provide energy dissipaters (e.g. riprap) along banks to minimize potential for erosion.
- ✓ Confine excavated materials to pervious surfaces away from lakes. Material must be covered if rain is expected.

## 6. Controlling Illegal Dumping

Illegally dumped wastes can cause storm water and lake water quality problems. Non-hazardous solid wastes may include garbage, trash, refuse, paper, rubbish, ashes, industrial wastes, demolition and construction wastes, abandoned vehicles and parts thereof, discarded home and industrial appliances, manure, vegetable or animal solid and semi-solid wastes and other discarded solid or semi-solid waste provided that such wastes do not contain wastes which must be managed as hazardous wastes, or wastes which contain soluble pollutants in concentration which exceed applicable water quality objectives or could cause degradation of waters of the state.

### Field Investigation

- ✓ Report prohibited discharges such as dumping observed during the course of normal daily activities so they can be investigated, contained and cleaned up.
- ✓ Conduct field investigations to detect and eliminate improper disposal of pollutants into the storm drain (i.e. identify problem areas where discharges or illegal connections may occur and follow up stream to determine the source(s)).
- ✓ Report all observed illicit connections and discharges to the City's NPDES Program Manager or to the City's 24 hour water pollution reporting hotline (714) 538-1961.
- ✓ Encourage public reporting of improper waste disposal by distributing public education materials and advertising the 24-hour water pollution problem reporting hotline.

### OPTIONAL:

- Post "No Dumping" signs in problem areas with a phone number for reporting dumping and disposal.

## 7. Bacteria Control

- ✓ Eliminate or reduce the feeding of waterfowl (i.e., ducks and geese).
- ✓ When feeding waterfowl, use food designated for waterfowl (no bread or crackers).

### OPTIONAL:

- Place signage by lake with the above recommendations (see attached example)

## 8. Monitoring

### OPTIONAL:

- Monitor fecal coliform.
- Monitor nutrient levels of both the water body and the soil.
- Monitor all trace metals found present in the soil and the water.

---

## LIMITATIONS:

Alternative pest/weed controls may not be available, suitable, or effective in every case. Clean-up activities may create a slight disturbance for local aquatic species. If the lake is recognized as a wetland, many activities, including maintenance, may be subject to regulation and permitting.

## REFERENCES:

*California Storm Water Best Management Practice Handbooks. Industrial/Commercial Best Management Practice Handbook. Prepared by Camp Dresser & McKee, Larry Walker Associates, Uribe and Associates, Resources Planning Associates for Stormwater Quality Task Force. July 1993.*

County of Orange. 2000. Public Facilities and Resources Department, Management Guidelines for the Use of Fertilizers and Pesticides. September.

King County Stormwater Pollution Control Manual. Best Management Practices for Businesses. 1995. King County Surface Water Management. July. On-line: <http://dnr.metrokc.gov/wlr/dss/spcm.htm>

Los Angeles County Stormwater Quality Model Programs. Public Agency Activities  
[http://ladpw.org/wmd/npdes/model\\_links.cfm](http://ladpw.org/wmd/npdes/model_links.cfm)

Model Urban Runoff Program: A How-To Guide for Developing Urban Runoff Programs for Small Municipalities. Prepared by City of Monterey, City of Santa Cruz, California Coastal Commission, Monterey Bay National Marine Sanctuary, Association of Monterey Bay Area Governments, Woodward-Clyde, Central Coast Regional Water Quality Control Board. July. 1998.

Santa Clara Valley Urban Runoff Pollution Prevention Program. 1997 Urban Runoff Management Plan. September 1997, updated October 2000.

California Storm Water Best Management Practice Handbooks. Municipal Best Management Practice Handbook. Prepared by Camp Dresser & McKee, Larry Walker Associates, Uribe and Associates, Resources Planning Associates for Stormwater Quality Task Force. March 1993.

Harvard University. 2002. Solid Waste Container Best Management Practices – Fact Sheet On-Line Resources – Environmental Health and Safety.

Bay Area Stormwater Management Agencies Association. 1996. Pollution From Surface Cleaning.

Oregon Association of Clean Water Agencies. Oregon Municipal Stormwater Toolbox for Maintenance Practices. June 1998.

San Diego Stormwater Copermittees Jurisdictional Urban Runoff Management Plan. 2001. Municipal Activities Model Program Guidance. November.

Santa Clara Valley Urban Runoff Pollution Prevention Program. Maintenance Best Management Practices for the Construction Industry. Brochures: Landscaping, Gardening, and Pool; Roadwork and Paving; and Fresh Concrete and Mortar Application. June 2001.

County of Orange Environmental Resource Department.



**FP-2**

## **LANDSCAPE MAINTENANCE**

**The model procedures described below focus on minimizing the discharge of pesticides and fertilizers, landscape waste, trash, debris, and other pollutants to the storm drain system and receiving waters. Landscape maintenance practices may involve one or more of the following activities:**

- 1. Mowing, Trimming/Weeding, and Planting**
- 2. Irrigation**
- 3. Fertilizer and Pesticide Management**
- 4. Managing Landscape Waste**
- 5. Erosion Control**

### **POLLUTION PREVENTION:**

Pollution prevention measures have been considered and incorporated in the procedures. Implementation of these measures may be more effective and reduce or eliminate the need to implement other more complicated or costly procedures. Possible pollution prevention measures for landscape maintenance include:

- Implement an integrated pest management (IPM) program. IPM is a sustainable approach to managing pests by combining biological, cultural, physical, and chemical tools.
- Choose low water using flowers, trees, shrubs, and groundcover.
- Appropriate maintenance (i.e. properly timed fertilizing, weeding, pest control, and pruning) will preserve the landscapes water efficiency.
- Educate municipal staff on pollution prevention measures.



## MODEL PROCEDURES:

### 1. Mowing, Trimming/Weeding, and Planting

#### Mowing, Trimming/Weeding

- ✓ Whenever possible, use mechanical methods of vegetation removal rather than applying herbicides. Use hand weeding where practical.
- ✓ When conducting mechanical or manual weed control, avoid loosening the soil, which could erode into streams or storm drains.
- ✓ Use coarse textured mulches or geotextiles to suppress weed growth and reduce the use of herbicides.
- ✓ Do not blow or rake leaves, etc. into the street or place yard waste in gutters or on dirt shoulders. Sweep up any leaves, litter or residue in gutters or on street.
- ✓ Collect lawn and garden clippings, pruning waste, tree trimmings, and weeds. Chip if necessary, and compost or dispose of at a landfill (see waste management section of this procedure sheet).
- ✓ Place temporarily stockpiled material away from watercourses, and berm or cover stockpiles to prevent material releases to storm drains.

#### Planting

- ✓ Where feasible, retain and/or plant selected native vegetation whose features are determined to be beneficial. Native vegetation usually requires less maintenance (e.g., irrigation, fertilizer) than planting ornamental vegetation.
- ✓ When planting or replanting consider using low water use groundcovers.

#### OPTIONAL:

- Careful soil mixing and layering techniques using a topsoil mix or composted organic material can be used as an effective measure to reduce herbicide use and watering.

## 2. Irrigation

- ✓ Utilize water delivery rates that do not exceed the infiltration rate of the soil.
- ✓ Use timers appropriately or a drip system to prevent runoff and then only irrigate as much as is needed.
- ✓ Inspect irrigation system periodically to ensure that the right amount of water is being applied and that excessive runoff is not occurring. Minimize excess watering, and repair leaks in the irrigation system as soon as they are observed.
- ✓ Where practical, use automatic timers to minimize runoff.
- ✓ Use popup sprinkler heads in areas with a lot of activity or where there is a chance the pipes may be broken. Consider the use of mechanisms that reduce water flow to sprinkler heads if broken.
- ✓ If re-claimed water is used for irrigation, ensure that there is no runoff from the landscaped area(s).
- ✓ If bailing of muddy water is required (e.g. when repairing a water line leak), do not put it in the storm drain; pour over landscaped areas.

## 3. Fertilizer and Pesticide Management

### Usage

- ✓ Utilize a comprehensive management system that incorporates integrated pest management techniques.
- ✓ Follow all federal, state, and local laws and regulations governing the use, storage, and disposal of fertilizers and pesticides and training of applicators and pest control advisors.
- ✓ Educate and train employees on use of pesticides and in pesticide application techniques to prevent pollution.
- ✓ Pesticide application must be under the supervision of a California qualified pesticide applicator.
- ✓ When applicable use the least toxic pesticides that will do the job. Avoid use of copper-based pesticides if possible.
- ✓ Do not mix or prepare pesticides or fertilizers for application near storm drains.
- ✓ Prepare the minimum amount of pesticide needed for the job and use the lowest rate that will effectively control the pest.
- ✓ Employ techniques to minimize off-target application (e.g. spray drift) of pesticides, including consideration of alternative application techniques.
- ✓ Calibrate fertilizer and pesticide application equipment to avoid excessive application.
- ✓ Periodically test soils for determining proper fertilizer use.

- ✓ Sweep pavement and sidewalk if fertilizer is spilled on these surfaces before applying irrigation water.
- ✓ Inspect pesticide/fertilizer equipment and transportation vehicles daily.

#### OPTIONAL:

- Work fertilizers into the soil rather than dumping or broadcasting them onto the surface.
- Use beneficial insects where possible to control pests (green lacewings, ladybugs, praying mantis, ground beetles, parasitic nematodes, trichogramma wasps, seedhead weevils, and spiders prey on detrimental pest species).
- Use slow release fertilizers whenever possible to minimize leaching.

#### **Scheduling**

- ✓ Do not use pesticides if rain is expected within 24 hours.
- ✓ Apply pesticides only when wind speeds are low (less than 5 mph).

#### **Disposal**

- ✓ Purchase only the amount of pesticide that you can reasonably use in a given time period (month or year depending on the product).
- ✓ Triple rinse containers, and use rinse water as product. Dispose of unused pesticide as hazardous waste.
- ✓ Dispose of empty pesticide containers according to the instructions on the container label.

## **4. Managing Landscape Waste**

*Also see Waste Handling and Disposal procedure sheet*

- ✓ Compost leaves, sticks, or other collected vegetation or dispose of at a permitted landfill. Do not dispose of collected vegetation into waterways or storm drainage systems.
- ✓ Place temporarily stockpiled material away from watercourses and storm drain inlets, and berm or cover stockpiles to prevent material releases to the storm drain system.
- ✓ Reduce the use of high nitrogen fertilizers that produce excess growth requiring more frequent mowing or trimming.
- ✓ Inspection of drainage facilities should be conducted to detect illegal dumping of clippings/cuttings in or near these facilities. Materials found should be picked up and properly disposed of.
- ✓ Landscape wastes in and around storm drain inlets should be avoided by either using bagging equipment or by manually picking up the material.

## 5. Erosion Control

*Also see Waste Handling and Disposal procedure sheet*

- ✓ Maintain vegetative cover on medians and embankments to prevent soil erosion. Apply mulch or leave clippings to serve as additional cover for soil stabilization and to reduce the velocity of storm water runoff.
- ✓ Minimize the use of disking as a means of vegetation management because the practice may result in erodable barren soil.
- ✓ Confine excavated materials to pervious surfaces away from storm drain inlets, sidewalks, pavement, and ditches. Material must be covered if rain is expected.

---

### LIMITATIONS:

Alternative pest/weed controls may not be available, suitable, or effective in every case.

### REFERENCES:

*California Storm Water Best Management Practice Handbooks. Industrial/Commercial Best Management Practice Handbook. Prepared by Camp Dresser & McKee, Larry Walker Associates, Uribe and Associates, Resources Planning Associates for Stormwater Quality Task Force. July 1993.*

County of Orange. 2000. Public Facilities and Resources Department, Management Guidelines for the Use of Fertilizers and Pesticides. September.

King County Stormwater Pollution Control Manual. Best Management Practices for Businesses. 1995. King County Surface Water Management. July. On-line: <http://dnr.metrokc.gov/wlr/dss/spcm.htm>

Los Angeles County Stormwater Quality Model Programs. Public Agency Activities [http://ladpw.org/wmd/npdes/model\\_links.cfm](http://ladpw.org/wmd/npdes/model_links.cfm)

Model Urban Runoff Program: A How-To Guide for Developing Urban Runoff Programs for Small Municipalities. Prepared by City of Monterey, City of Santa Cruz, California Coastal Commission, Monterey Bay National Marine Sanctuary, Association of Monterey Bay Area Governments, Woodward-Clyde, Central Coast Regional Water Quality Control Board. July. 1998.

Santa Clara Valley Urban Runoff Pollution Prevention Program. 1997 Urban Runoff Management Plan. September 1997, updated October 2000.



## **ROADS, STREETS, AND HIGHWAYS OPERATION AND MAINTENANCE**

**Streets, roads, and highways are significant sources of pollutants in storm water discharges, and operation and maintenance (O&M) practices, if not conducted properly, can contribute to the problem. O&M practices may involve one or more of the following activities:**

- 1. Sweeping & Cleaning**
- 2. Street Repair & Maintenance**
- 3. Bridge and Structure Maintenance**

### **POLLUTION PREVENTION:**

Pollution prevention measures have been considered and incorporated in the procedures. Implementation of these measures may be more effective and reduce or eliminate the need to implement other more complicated or costly procedures. Possible pollution prevention measure for roads, streets, and highways operation and maintenance include:

- Use the least toxic materials available (e.g. water based paints, gels or sprays for graffiti removal)
- Recycle paint and other materials whenever possible.
- Educate municipal staff on pollution prevention measures.

## MODEL PROCEDURES:

### 1. Sweeping & Cleaning

#### Sweeping Frequency and Timing

- ✓ Maintain a consistent sweeping schedule. Provide minimum monthly sweeping of streets.
- ✓ Perform street cleaning during dry weather if possible.
- ✓ Avoid wet cleaning or flushing of streets, and utilize dry methods where possible.
- ✓ If flushing of a street is absolutely necessary, sweep and remove debris before flushing. Do not let wash water enter storm drain inlets. Collect wash water and direct to a dirt or vegetated area, pump into a vacuum truck and dispose of properly.

#### OPTIONAL:

- Consider increasing sweeping frequency based on factors such as traffic volume, land use, field observations of sediment and trash accumulation, proximity to water courses, etc.

#### Equipment Operation and Selection

→ *Note: Permission must be obtained for any discharge of wash water to the sanitary sewer from the local sewerage agency.*

- ✓ Maintain cleaning equipment in good working condition and purchase replacement equipment as needed. Old sweepers should be replaced as needed with new technologically advanced sweepers (preferably regenerative air sweepers) that maximize pollutant removal.
- ✓ Operate sweepers at manufacturer requested optimal speed levels to increase effectiveness.
- ✓ Clean sweepers at a wash rack that drains to the sanitary sewer. The wash rack area should be covered and bermed and wash water should drain to a clarifier prior to entering the sanitary sewer.
- ✓ Regularly inspect vehicles and equipment for leaks, and repair immediately.

#### OPTIONAL:

- If available use vacuum or regenerative air sweepers in the high sediment and trash areas (typically industrial/commercial).

#### Management of Material Removed by Sweeping

- ✓ Dispose of street sweeping debris and dirt at a landfill.
- ✓ Do not store swept material along the side of the street or near a storm drain inlet.
- ✓ If dewatering of saturated materials is necessary it should be conducted in a designated area away from storm drain inlets and the water contained for proper disposal.

→ *Note: Permission must be obtained for any discharge of wash water to the sanitary sewer from the local sewerage agency.*

## Maximize Access for Sweepers

- ✓ If authorized by the local sanitation agency, water may be discharged to the sanitary sewer only after passing through a clarifier. As an alternative, dewatering can be conducted in a containment area in which saturated materials are placed on a tarp and allowed to dry. Dry debris is then disposed of properly.
- ✓ Keep debris storage to a minimum during the wet season or make sure debris piles are contained (e.g. by berming the area) or covered (e.g. with tarps or permanent covers).
- ✓ Keep accurate operation logs to track program.
- ✓ Properly maintain and operate equipment; which will increase efficiency.
- ✓ Sweeping should be conducted as close to the curb line as possible.

### OPTIONAL:

- Institute a parking policy to restrict parking in problematic areas during periods of street sweeping.
- Post permanent street sweeping signs in problematic areas; use temporary signs if installation of permanent signs is not possible.
- Develop and distribute flyers notifying residents of street sweeping schedules.

## 2. Repair and Maintenance

### Pavement Marking

- ✓ Develop paint handling procedures for proper use, storage, and disposal of paints.
- ✓ Transfer and load paint and hot thermoplastic away from storm drain inlets.
- ✓ Street or hand sweep thermoplastic grindings. Yellow thermoplastic grindings may require special handling as they may contain lead.
- ✓ Replace paints containing lead and tributyltin with less toxic alternatives.
- ✓ Use water based paints. Clean application equipment in a sink that is connected to the sanitary sewer.
- ✓ Properly store leftover paints if they are to be kept for the next job, or dispose of properly.
- ✓ See *Spill Control procedure sheet* for guidance on the proper cleanup of paint spills.

## Concrete Installation and Repair

- ✓ Avoid mixing excess amounts of fresh concrete or cement mortar on-site. Only mix what is needed for the job.
- ✓ Wash concrete trucks off site or in designated areas on site, such that there is no discharge of concrete wash water into storm drain inlets, open ditches, streets, or other stormwater conveyance structures.
- ✓ Store concrete materials under cover, away from drainage areas.
- ✓ Return leftover materials to the transit mixer. Dispose of small amounts of hardened excess concrete, grout, and mortar in the trash.
- ✓ Do not wash sweepings from exposed aggregate concrete into the street or storm drain. Collect and return sweepings to aggregate base stockpile, or dispose in the trash.
- ✓ When washing poured concrete areas to remove fine particles and expose the aggregate, contain the wash water for proper disposal; do not discharge water to the storm drain system.
- ✓ Do not allow excess concrete to be dumped on-site, except in designated areas.
- ✓ Apply concrete, asphalt, and seal coat during dry weather to allow the material to adequately dry prior to a rain event.
- ✓ When making saw cuts in pavement, use as little water as possible and perform during dry weather. Cover each nearby or appropriate storm drain inlet completely with filter fabric or plastic during the sawing operation and contain the slurry by placing straw bales, sandbags, or gravel dams around the inlets. After the liquid drains or evaporates, shovel or vacuum the slurry residue from the pavement or gutter and remove from site. Alternatively, a small on-site vacuum may be used to pick up the slurry as this will prohibit slurry from reaching storm drain inlets.

## Patching, Resurfacing, and Surface Sealing

- ✓ Pre-heat, transfer or load hot bituminous material away from storm drain inlets.
- ✓ Apply concrete, asphalt, and seal coat during dry weather to allow the material to adequately dry prior to a rain event.
- ✓ Where applicable, cover and seal each nearby or appropriate storm drain inlet (with waterproof material, plastic or mesh) and maintenance holes before applying seal coat, slurry seal, etc. Leave covers in place until job is complete and until all water from emulsified oil sealants has drained or evaporated. Clean any debris from covered man holes and storm drain inlets when the job is complete.
- ✓ Use only as much water as necessary for dust control, to avoid runoff.
- ✓ Catch drips from paving equipment that is not in use with pans or absorbent material placed under the machines. Dispose of collected material and absorbents properly.



## Equipment Cleaning, Maintenance, and Storage

*Also see Equipment Repair & Maintenance procedure sheet.*

→ *Note: Permission must be obtained for any discharge of wash water to the sanitary sewer from the local sewerage agency.*

- ✓ Prior to a rain event or at the completion of a project, sweep the project area by hand or with a street sweeper.
- ✓ Clean equipment including sprayers, sprayer paint supply lines, patch and paving equipment, and mudjacking equipment at the end of each day. If equipment can be cleaned and materials reapplied at the job site, do so in compliance with the laws and regulations. Clean in a sink or other area (e.g. vehicle wash area) that is connected to the sanitary sewer.
- ✓ If refueling or repairing vehicles and equipment must be done on-site, conduct the activity away from storm drain inlets and watercourses.
- ✓ Place drip pans or absorbent materials under heavy equipment when not in use.
- ✓ Clean paint brushes and tools covered with water-based paints in sinks connected to sanitary sewers. Brushes and tools covered with non-water-based paints, finishes, or other materials must be cleaned in a manner that enables collection of used solvents (e.g., paint thinner, turpentine, etc.) for recycling or proper disposal.

### OPTIONAL:

- Conduct cleaning at a corporation or maintenance yard if possible.
- When practical, perform major equipment repairs at the corporation yard.

→ *In addition to the procedures above, review and apply general procedures outlined for Minor Construction activities when conducting street, road, and highway repair and maintenance activities.*

## 3. Bridge and Structure Maintenance

### Painting and Paint Removal

- ✓ Transport paint and materials to and from job sites in containers with secure lids and tied down to the transport vehicle.
- ✓ Do not transfer or load paint near storm drain inlets or watercourses.
- ✓ Test and inspect spray equipment prior to starting to paint. Tighten all hoses and connections and do not overfill paint container.
- ✓ If sand blasting is used to remove paint, cover nearby storm drain inlets prior to starting work.
- ✓ If the bridge crosses a watercourse, perform work on a maintenance traveler or platform, or use suspended netting or tarps to capture paint, rust, paint removing agents, or other materials, to prevent discharge of materials to surface waters. If sanding, use a sander with a vacuum filter bag.

Recycle paint when possible (e.g. paint may be used for graffiti removal activities). Dispose of paint at an appropriate household hazardous waste facility.

## Graffiti Removal

- ✓ Avoid graffiti abatement activities during rain events.
- ✓ Protect nearby storm drain inlets prior to removing graffiti from walls, signs, sidewalks, or other structures needing graffiti abatement. Clean up afterwards by sweeping or vacuuming thoroughly, and/or by using absorbent and properly disposing of the absorbent.
- ✓ Note that care should be taken when disposing of waste since it may need to be disposed of as hazardous waste.
- ✓ When graffiti is removed by painting over, implement the procedures under Painting and Paint Removal above.
- ✓ Direct runoff from sand blasting and high pressure washing (with no cleaning agents) into a landscaped or dirt area.
- ✓ If a graffiti abatement method generates wash water containing a cleaning compound (such as high pressure washing with a cleaning compound), plug nearby storm drains and collect wash water and dispose of properly.

### OPTIONAL:

- Consider using a waterless and non-toxic chemical cleaning method for graffiti removal (e.g. gels or spray compounds).

## Guardrail and Fence Repair

- ✓ When cleaning guardrails or fences follow the appropriate surface cleaning methods (depending on the type of surface) outlined in the *Sidewalk, Plaza, and Fountain Maintenance and Cleaning* procedure sheet.
- ✓ If painting is conducted, follow the *Painting and Paint Removal* procedures above.
- ✓ If graffiti removal is conducted, follow the *Graffiti Removal* procedures above.
- ✓ If construction takes place, see the procedure sheet for *Minor Construction*.
- ✓ Recycle materials whenever possible.

---

## LIMITATIONS:

Limitations related to street sweeping may include high equipment costs, the potential inability to restrict parking in urban areas, the need for sweeper operator training, the inability of current sweeper technology to remove oil and grease, and the lack of scientific evidence regarding the expected levels of pollutant removal.

## REFERENCES:

*Model Urban Runoff Program: A How-To Guide for Developing Urban Runoff Programs for Small Municipalities. Prepared by City of Monterey, City of Santa Cruz, California Coastal Commission, Monterey Bay National Marine Sanctuary, Association of Monterey Bay Area Governments, Woodward-Clyde, Central Coast Regional Water Quality Control Board. July. 1998.*

Oregon Association of Clean Water Agencies. Oregon Municipal Stormwater Toolbox for Maintenance Practices. June 1998.

Santa Clara Valley Urban Runoff Pollution Prevention Program. 1997 Urban Runoff Management Plan. September 1997, updated October 2000.



**FP-4**

## **SIDEWALK, PLAZA, AND FOUNTAIN MAINTENANCE AND CLEANING**

**Pollutants on sidewalks and other pedestrian traffic areas and plazas are typically due to littering and vehicle use. Fountain water containing chlorine and copper-based algaecides is toxic to aquatic life. Proper inspection, cleaning, and repair of pedestrian areas and city surfaces and structures can reduce pollutant runoff from these areas. Maintaining these areas may involve one or more of the following activities:**

- 1. Surface Cleaning**
- 2. Graffiti Cleaning**
- 3. Sidewalk Repair**
- 4. Controlling Litter**
- 5. Fountain Maintenance**

### **POLLUTION PREVENTION:**

Pollution prevention measures have been considered and incorporated in the procedures. Implementation of these measures may be more effective and reduce or eliminate the need to implement other more complicated or costly procedures. Possible pollution prevention measures for sidewalk, plaza, and fountain maintenance and cleaning include:

- Use dry cleaning methods whenever practical for surface cleaning activities.
- Use the least toxic materials available (e.g. water based paints, gels or sprays for graffiti removal).
- Educate municipal staff on pollution prevention measures.

## MODEL PROCEDURES:

### 1. Surface Cleaning

Discharges of wash water to the storm water drainage system from cleaning or hosing of impervious surfaces is prohibited.

#### Sidewalks, Plazas

- ✓ Use dry methods (e.g. sweeping, backpack blowers, vacuuming) whenever practical to clean sidewalks and plazas rather than hosing, pressure washing, or steam cleaning. DO NOT sweep or blow material into curb; use devices that contain the materials.
- ✓ If water must be used, block storm drain inlets and contain runoff. Discharge wash water to landscaping or contain and dispose of properly.

#### Parking Areas, Driveways, Drive-thru

- ✓ Parking facilities should be swept/vacuumed on a regular basis. Establish frequency of public parking lot sweeping based on usage and field observations of waste accumulation.
- ✓ If water must be used, block storm drain inlets and contain runoff. Discharge wash water to landscaping or contain and dispose of properly.
- ✓ Sweep all parking lots at least once before the onset of the wet season.
- ✓ Use absorbents to pick up oil; then dry sweep.
- ✓ Appropriately dispose of spilled materials and absorbents.

#### OPTIONAL:

- Consider increasing sweeping frequency based on factors such as traffic volume, land use, field observations of sediment and trash accumulation, proximity to water courses, etc.

#### Building Surfaces, Decks, etc., without loose paint

- ✓ Use high-pressure water, no soap.
- ✓ If water must be used, block storm drain inlets and contain runoff. Discharge wash water to landscaping or contain and dispose of properly.

#### Unpainted Building Surfaces, Wood Decks, etc.

- ✓ If water must be used, block storm drain inlets and contain runoff. Discharge wash water to landscaping or contain and dispose of properly.
- ✓ Use a biodegradable cleaning agent or acid wash to remove deposits, wood restorer, or other chemicals. Screen wash water using an appropriate filtering device (e.g. filter fabric), if needed, to catch debris.
- ✓ Make sure pH is between 6.5 and 8.5 THEN discharge to landscaping (if cold water without a cleaning agent) otherwise dispose of properly.

## 2. Graffiti Cleaning

### Graffiti Removal

*See Roads, Streets, and Highways Operation and Maintenance procedure sheet.*

- ✓ Avoid graffiti abatement activities during rain events.
- ✓ When graffiti is removed by painting over, implement the procedures under Painting and Paint Removal in the *Roads, Streets, and Highway Operation and Maintenance* procedure sheet.
- ✓ Protect nearby storm drain inlets prior to removing graffiti from walls, signs, sidewalks, or other structures needing graffiti abatement. Clean up afterwards by sweeping or vacuuming thoroughly, and/or by using absorbent and properly disposing of the absorbent.
- ✓ Note that care should be taken when disposing of waste since it may need to be disposed of as hazardous waste.

#### OPTIONAL:

- Consider using a waterless and non-toxic chemical cleaning method for graffiti removal (e.g. gels or spray compounds).

## 3. Sidewalk Repair

### Surface Removal and Repair

*Also see the street sweeping section of the Roads, Streets, and Highways Operation and Maintenance procedure sheet.*

- ✓ Schedule surface removal activities for dry weather if possible.
- ✓ Avoid creating excess dust when breaking asphalt or concrete.
- ✓ Take measures to protect nearby storm drain inlets prior to breaking up asphalt or concrete (e.g. place hay bales or sand bags around inlets). Clean afterwards by sweeping up material.
- ✓ Designate an area for clean up and proper disposal of excess materials.
- ✓ Remove and recycle as much of the broken pavement as possible.
- ✓ When making saw cuts in pavement, use as little water as possible. Cover each storm drain inlet with filter fabric during the sawing operation and contain the slurry by placing straw bales, sandbags, or gravel dams around the inlets. After the liquid drains shovel or vacuum the slurry, remove from site and dispose of properly.
- ✓ Always dry sweep first to clean up tracked dirt. Use a street sweeper or vacuum truck. Do not dump vacuumed liquid in storm drains. Once dry sweeping is complete, the area may be hosed down if needed. Discharge wash water to landscaping, pump to the sanitary sewer if permitted to do so or contain and dispose of properly.

## Concrete Installation and Repair

*See Roads, Streets, and Highways Operation and Maintenance procedure sheet.*

- ✓ Avoid mixing excess amounts of fresh concrete or cement mortar on-site. Only mix what is needed for the job.
- ✓ Wash concrete trucks off-site or in designated areas on-site, such that there is no discharge of concrete wash water into storm drain inlets, open ditches, streets, or other storm water conveyance structures.
- ✓ Store dry and wet concrete materials under cover, protected from rainfall and runoff and away from drainage areas. After job is complete remove temporary stockpiles (asphalt materials, sand, etc.) and other materials as soon as possible.
- ✓ Return leftover materials to the transit mixer. Dispose of small amounts of excess concrete, grout, and mortar in the trash.
- ✓ When washing concrete to remove fine particles and expose the aggregate, contain the wash water for proper disposal.
- ✓ Do not wash sweepings from exposed aggregate concrete into the street or storm drain. Collect and return sweepings to aggregate base stock pile, or dispose in the trash.
- ✓ Protect applications of fresh concrete from rainfall and runoff until the material has hardened.

## 4. Litter Control

- ✓ Enforce anti-litter laws.
- ✓ Provide litter receptacles in busy, high pedestrian traffic areas of the community, at recreational facilities, and at community events.
- ✓ Cover litter receptacles and clean out frequently to prevent leaking/spillage or overflow.

OPTIONAL:

- Post "No Littering" signs.

## 5. Fountain Maintenance

- ✓ Do not use copper-based algaecides. Control algae with chlorine or other alternatives, such as sodium bromide.
- ✓ When draining fountains, never discharge water to a street or storm drain; discharge to the sanitary sewer
- ✓ Allow chlorine to dissipate for a few days and then recycle/reuse water by draining it gradually onto a landscaped area. Water must be tested prior to discharge to ensure that chlorine is not present (concentration must be less than 0.1 ppm).

---

## **LIMITATIONS:**

Surface cleaning activities that require discharges to the local sanitation agency will require coordination with the agency.

## **REFERENCES:**

Bay Area Stormwater Management Agencies Association. 1996. Pollution From Surface Cleaning.

*Model Urban Runoff Program: A How-To Guide for Developing Urban Runoff Programs for Small Municipalities. Prepared by City of Monterey, City of Santa Cruz, California Coastal Commission, Monterey Bay National Marine Sanctuary, Association of Monterey Bay Area Governments, Woodward-Clyde, Central Coast Regional Water Quality Control Board. July. 1998.*

Oregon Association of Clean Water Agencies. Oregon Municipal Stormwater Toolbox for Maintenance Practices. June 1998.

San Diego Stormwater Co-permittees Jurisdictional Urban Runoff Management Plan. 2001. Municipal Activities Model Program Guidance. November.

Santa Clara Valley Urban Runoff Pollution Prevention Program. 1997 Urban Runoff Management Plan. September 1997, updated October 2000.

Santa Clara Valley Urban Runoff Pollution Prevention Program. Maintenance Best Management Practices for the Construction Industry. Brochures: Landscaping, Gardening, and Pool; Roadwork and Paving; and Fresh Concrete and Mortar Application. June 2001.





## SOLID WASTE HANDLING

It is important to control litter to eliminate trash and other materials in storm water runoff. Waste reduction is a major component of waste management and should be encouraged through training and public outreach. Management of waste once it is collected may involve reuse, recycling, or proper disposal. Specific solid waste handling activities may include one or more of the following:

1. Solid Waste Collection
2. Waste Reduction and Recycling
3. Hazardous Waste Collection
4. Litter Control

**Reduce** by purchasing only the amount needed.  
**Reuse** products when possible.  
**Recycle** leftover products that are recyclable, and dispose of other wastes safely.

### POLLUTION PREVENTION:

Pollution prevention measures have been considered and incorporated in the procedures. Implementation of these measures may be more effective and reduce or eliminate the need to implement other more complicated or costly procedures. Possible pollution prevention measures for solid waste handling include:

- Reuse products when possible.
- Recycle leftover products that are recyclable.
- Educate municipal staff on pollution prevention measures.

### MODEL PROCEDURES:

#### 1. Solid Waste Collection

- ✓ Implement procedures, where applicable, to collect, transport, and dispose of solid waste at appropriate disposal facilities in accordance with applicable federal, state, and local laws and regulations. Optional disposal options include the reuse and recycling of appropriate materials (see following sections).

- ✓ Include properly designed trash storage areas.
- ✓ Regularly inspect solid waste containers for structural damage. Repair or replace damaged containers as necessary.
- ✓ Secure solid waste containers; containers must be closed tightly when not in use.
- ✓ Do not fill waste containers with washout water or any other liquid.
- ✓ Remove all debris from containers prior to cleaning with water. Only clean out containers in a designated area that drains to a landscaped area or a washrack that is connected to a sanitary sewer.
- ✓ Minimize spillage/leaking from solid waste containers. For larger solid waste containers (especially compactors) that utilize a hydraulic fluid pump system, regularly inspect and replace faulty pumps or hoses to minimize the potential of releases and spills.
- ✓ Ensure that only appropriate solid wastes are disposed of. Certain wastes such as hazardous wastes, appliances, fluorescent bulbs, pesticides, etc. may not be disposed of in solid waste containers.

*Also see Emergency Spill Response procedure sheet.*

## 2. Waste Reduction and Recycling

Although many types of waste can be recycled, recycling options for each waste type may be limited. All gasoline, antifreeze, waste oil, and lead-acid batteries can be recycled. Latex and oil-based paint can be reused, as well as recycled. Materials that cannot be reused or recycled should be disposed of properly.

- ✓ Provide containers for the collection and storage of recyclable materials.
- ✓ Do not mix liquid wastes, this can cause chemical reactions or make recycling impossible and complicate disposal.
- ✓ Recycle used motor oil. Municipalities are required to have a used oil recycling element within their integrated waste management plan.

→ *The California Department of Resources Recycling and Recovery (CalRecycle) has a used oil recycling hotline, 1(800) CLEAN UP, that provides information and recycling locations for used oil.*

## 3. Hazardous Waste Collection

Household hazardous wastes (HHW) are defined as waste materials which are typically found in homes or similar sources, which exhibit characteristics such as: corrosivity, ignitability, reactivity, and/or toxicity, or are listed as hazardous materials by EPA.

**List of most common HHW products:**

*Drain opener  
Oven cleaners  
Wood and metal cleaners and polishes  
Paint Thinners  
Automotive oil and fuel additives  
Adhesives  
Grease and rust solvents Batteries  
Herbicides  
Paint strippers and removers Pesticides  
Fungicides/wood preservatives  
Starter fluids  
Carburetor and fuel injection cleaners*

✓ Follow proper storage and disposal measures for hazardous waste materials as identified on packaging or Material Safety Data Sheets.

✓ Emergencies related to hazardous waste should be reported to 911

OPTIONAL:

- Identify and promote use of non-hazardous alternatives.
- Promote household hazardous waste (HHW) reuse and recycling.

## 4. Litter Control

✓ Enforce anti-litter laws.

✓ Provide litter receptacles in busy, high pedestrian traffic areas of the community, at recreational facilities, and at community events.

✓ Clean out and cover litter receptacles frequently to prevent overflow.

✓ Increase litter control for events generating substantial quantities of litter.

OPTIONAL:

- Post "No Littering" signs
- Place trash receptacles at transit stops and maintain as necessary.
- Participate in and/or organize additional clean up programs (e.g. "Coastal Clean Up Day", "Pride Days", "Volunteer Connection Days").

---

### LIMITATIONS:

Requires continuous public education.

## REFERENCES:

Bay Area Stormwater Management Agencies Association. 1996. Pollution From Surface Cleaning.

*California Storm Water Best Management Practice Handbooks. Municipal Best Management Practice Handbook. Prepared by Camp Dresser & McKee, Larry Walker Associates, Uribe and Associates, Resources Planning Associates for Stormwater Quality Task Force. March 1993.*

Environmental Protection Agency (EPA). Pollution Prevention and Good Housekeeping for Municipal Operations Storm Water. Pet Waste Collection. Office of Wastewater Management. Online:  
[http://www.epa.gov/npdes/menuofbmps/poll\\_3.htm](http://www.epa.gov/npdes/menuofbmps/poll_3.htm)

Harvard University. 2002. Solid Waste Container Best Management Practices – Fact Sheet On-Line Resources – Environmental Health and Safety.



**FP-6**

## **WATER AND SEWER UTILITY OPERATION AND MAINTENANCE**

**Although sewage systems and the operation and maintenance of public utilities are not considered themselves to be chronic sources of stormwater pollution, some activities and accidents can result in the discharge of raw sewage. Sewage contains pollutants that can pose a threat to both human health and the quality of receiving waters if they enter the storm drain system through incidents such as spills, leaks or overflows. Activities associated with the operation and maintenance of water and sewer utilities to prevent and handle such incidents include the following:**

- 1. Water Line Maintenance**
- 2. Sanitary Sewer Maintenance**
- 3. Spill/Leak/Overflow Control, Response, and Containment**

**Cities that do not provide maintenance of water and sewer utilities should coordinate with the contracting agency responsible for these activities and ensure that these procedures are followed.**

### **POLLUTION PREVENTION:**

Pollution prevention measures have been considered and incorporated in the procedures. Implementation of these measures may be more effective and reduce or eliminate the need to implement other more complicated or costly procedures. Possible pollution prevention measures for water and sewer utility operation and maintenance include:

- Inspect potential non-storm water discharge flow paths and clear/cleanup any debris or pollutants found (i.e. remove trash, leaves, sediment, and wipe up liquids, including oil spills).
- Educate municipal staff on pollution prevention measures.

## MODEL PROCEDURES:

### 1. Water Line Maintenance

Procedures can be employed to reduce pollutants from discharges associated with water utility operation and maintenance activities. Planned discharges may include fire hydrant testing, flushing water supply mains after new construction, flushing lines due to complaints of taste and odor, dewatering mains for maintenance work. Unplanned discharges from treated, recycled water, raw water, and groundwater systems operation and maintenance activities can occur from water main breaks, sheared fire hydrants, equipment malfunction, and operator error.

#### Planned Discharges

- ✓ For planned discharges use one of the following options:
  - Reuse water for dust suppression, irrigation, or construction compaction
  - Discharge to the sanitary sewer system with approval
  - Discharge to the storm drain system or to a creek using applicable pollution control measures listed below (this option is ONLY applicable to uncontaminated pumped ground water, water line flushing, discharges from potable water sources other than water main breaks) and may require a permit from the Regional Water Quality Control Board.
- ✓ If water is discharged to a storm drain inlet (catch basin), control measures must be put in place to control potential pollutants (i.e. sediment, chlorine, etc.). Examples of some storm drain inlet protection options include:
  - Silt fence – appropriate where the inlet drains a relatively flat area.
  - Gravel and wire mesh sediment filter – Appropriate where concentrated flows are expected.
  - Wooden weir and fabric – use at curb inlets where a compact installation is desired.
- ✓ Prior to discharge, inspect discharge flow path and clear/cleanup any debris or pollutants found (i.e. remove trash, leaves, sediment, and wipe up liquids, including oil spills).
- ✓ Select appropriate pollution control measure(s) considering the receiving system (i.e. curb inlet, drop inlet, culvert, creek, etc.) and ensure that the control device(s) fit properly.

- ✓ General design considerations for inlet protection devices include the following:
  - The device should be constructed such that cleaning and disposal of trapped sediment is made easy, while minimizing interference with discharge activities.
  - Devices should be constructed so that any standing water resulting from the discharge will not cause excessive inconvenience or flooding/damage to adjacent land or structures.
- ✓ The effectiveness of control devices must be monitored during the discharge period and any necessary repairs or modifications made as needed.

#### OPTIONAL:

- Sediment removal may be enhanced by placing filter fabric, gravel bags, etc. at storm drain inlets.

## **Unplanned Discharges**

- ✓ Stop the discharge as quickly as possible by turning off water source.
- ✓ Inspect flow path of the discharged water:
  - Control erosion along the flow path.
  - Identify areas that may produce significant sediment or gullies, use sandbags to redirect the flow.
  - Identify erodible areas which may need to be repaired or protected during subsequent repairs or corrective actions
- ✓ If repairs or corrective action will cause additional discharges of water, select the appropriate procedures for erosion control, chlorine residual, turbidity, and chemical additives. Prevent potential pollutants from entering the flow path and ensure that no additional discharged water enters storm drain inlets.

## 2. Sanitary Sewer Maintenance

Applicable to municipalities who own and operate a sewage collection system. Facilities that are covered under this program include sanitary sewer pipes and pump stations owned and operated by the Permittee. The owner of the sanitary sewer facilities is the entity responsible for carrying out this prevention and response program.

### Sewer System Cleaning



- ✓ Sewer lines should be cleaned on a regular basis to remove grease, grit, and other debris that may lead to sewer backups.
- ✓ Establish routine maintenance program. Cleaning should be conducted at an established minimum frequency and more frequently for problem areas such as restaurants that are identified
- ✓ Cleaning activities may require removal of tree roots and other identified obstructions.

### Preventative and Corrective Maintenance

- ✓ During routine maintenance and inspection note the condition of sanitary sewer structures and identify areas that need repair or maintenance. Items to note may include the following:
  - cracked/deteriorating pipes
  - leaking joints/seals at manhole
  - frequent line plugs
  - line generally flows at or near capacity
  - suspected infiltration or exfiltration
- ✓ Document suggestions and requests for repair and report the information to the appropriate manager or supervisor.
- ✓ Prioritize repairs based on the nature and severity of the problem. Immediate clearing of blockage or repair is required where an overflow is currently occurring or for urgent problems that may cause an imminent overflow (e.g. pump station failures, sewer line ruptures, sewer line blockages). These repairs may be temporary until scheduled or capital improvements can be completed.
- ✓ Review previous sewer maintenance records to help identify "hot spots" or areas with frequent maintenance problems and locations of potential system failure.



## 3. Spill/Leak/Overflow Control, Response, and Containment

### Control

*Also see Drainage System procedures sheet*

- ✓ Refer to countywide *Illicit Discharge Detection and Elimination Program (DAMP Section 10)*. Components of this program include:
  - Investigation/inspection and follow-up
  - Elimination of illicit discharges and connections
  - Enforcement of ordinances
  - Respond to sewage spills
  - Facilitate public reporting of illicit discharges and connections. A citizen's hotline for reporting observed overflow conditions should be established to supplement the field screening efforts being conducted by the Principal Permittee.

### Response and Containment

- ✓ Establish lead department/agency responsible for spill response and containment. Provide coordination within departments.
- ✓ When a spill, leak, and/or overflow occurs, keep sewage from entering the storm drain system to the maximum extent practicable by covering or blocking storm drain inlets or by containing and diverting the sewage away from open channels and other storm drain facilities (using sandbags, inflatable dams, etc.).
- ✓ If a spill reaches the storm drain notify the Regional Water Quality Control Board and the County of Orange Health Care Agency through Control One at (714) 628-7208 (see DAMP Section 10).
- ✓ Remove the sewage using vacuum equipment or use other measures to divert it back to the sanitary sewer system.
- ✓ Record required information at the spill site.
- ✓ Perform field tests as necessary to determine the source of the spill.
- ✓ Develop additional notification procedures regarding spill reporting as needed.

---

### LIMITATIONS:

Private property access rights needed to perform testing along storm drain right-of-ways. Requirements of municipal ordinance authority for suspected source verification testing necessary for guaranteed rights of entry.

## REFERENCES:

*California Storm Water Best Management Practice Handbooks. Municipal Best Management Practice Handbook. Prepared by Camp Dresser & McKee, Larry Walker Associates, Uribe and Associates, Resources Planning Associates for Stormwater Quality Task Force. March 1993.*

Los Angeles County Stormwater Quality. Public Agency Activities Model Program. On-line:  
[http://ladpw.org/wmd/npdes/public\\_TC.cfm](http://ladpw.org/wmd/npdes/public_TC.cfm)

Santa Clara Valley Urban Runoff Pollution Prevention Program. 1997 Urban Runoff Management Plan. September 1997, updated October 2000.

Santa Clara Valley Urban Runoff Pollution Prevention Program. Water Utility Pollution Prevention Plan.

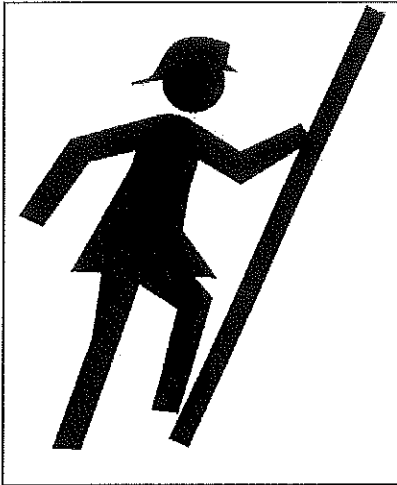

**FP-7**

## **FIRE DEPARTMENT ACTIVITIES**

**Although fire department activities are not considered a chronic source of stormwater pollution, some activities can result in the discharge of water containing pollutants that can pose a threat to both human health and the quality of receiving waters if they enter the storm drain system. Fire department activities include the following:**

- 1. Emergency Fire Fighting Activities**
- 2. Post-Emergency Fire Fighting Activities**
- 3. Fire Fighting Training Activities**
- 4. Fire Station Activities**
- 5. Fire Hydrant and Fire Sprinkler Testing**
- 6. Trauma Scene Clean-up**

**Cities that do not provide fire department services should coordinate with the agency responsible for these activities and ensure that these model procedures are followed.**

### **POLLUTION PREVENTION:**

Pollution prevention measures have been considered and incorporated in the model procedures. Implementation of these measures may be more effective and reduce or eliminate the need to implement other more complicated or costly procedures. Possible pollution prevention measures for fire department activities include:

- To the extent allowed by the circumstances at the scene and without compromising the health and safety of personnel or the public, inspect potential non-storm water discharge flow paths and clear/cleanup any debris or pollutants found (i.e. remove trash, leaves, sediment, and wipe up liquids, including oil spills).

## MODEL PROCEDURES:

### 1. Emergency Fire Fighting Activities

An "emergency" exists from alarm notification until, in the opinion of the incident commander, the emergency has concluded and emergency equipment is returned to the station. Discharges occurring during emergency fire fighting activities (i.e. flows necessary for the protection of life and property) do not require BMPs and are not prohibited under the stormwater permits. However, to the extent allowed by the circumstances at the scene and without compromising the health and safety of personnel or the public, emergency fire fighting activities should be performed in a manner that avoids or minimizes discharges to the storm water system.

BMPs that may be considered during emergency fire fighting activities include the following:

- Minimize the use of water on the fire and/or use foam;
- Block the storm drains that may be impacted to prevent the runoff from entering the storm drain system;
- Avoid directing fire fighting flows directly on erodible surfaces if runoff will enter receiving waters or storm drains;
- Apply fire fighting flows such that runoff will flow over vegetated areas prior to entering receiving waters or storm drains.

### 2. Post-Emergency Fire Fighting Activities

The post-emergency rehabilitation and maintenance of response equipment should be performed in a manner that prevents discharges to the storm water system whenever practicable, and minimizes discharges to the storm water system when elimination of discharges is practically unavoidable.

### 3. Fire Fighting Training Activities

Training activities, which simulate emergency responses, should be performed in a manner that reduces or prevents discharges to the storm water systems. In addition, when the elimination of discharges into the storm water system is unavoidable (i.e., equipment failures), measures should be implemented to minimize the potential impacts to water quality:

- Fire training should be conducted, where feasible, in facilities where runoff controls protecting the storm drain system have been engineered and built into the facility;
- Direct water flows to landscaped or green areas whenever possible and safe to do so without causing damage or erosion;

- When flowing water can not be contained in the landscaped areas, survey the area prior to the training exercise to ensure that debris and pollutants will not enter the storm water system as a result of the flows generated during the drill;
- When practicable and necessary, divert flows to the sewer, with the permission of the local sewerage agency;
- Use fog streams for short durations;
- Use lower gallon per minute (GPM) nozzle settings;
- Prevent discharge of foam to the storm drain system. If training activities involve the use of foam, seal all potentially affected storm drain inlets with plastic sheeting and sandbags or temporary berms, collect the runoff, apply a defoaming agent, and discharge to the sanitary sewer, with the permission of the local sewerage agency;
- Pre-plan live fire training activities to allow integration of structural BMPs to control runoff.

## 4. Fire Station Activities

Fire stations are identified in the Drainage Area Management Plan (DAMP) as a Municipal Fixed Facility. Potential pollutant generating activities typically performed at fire stations that could result in discharge of pollutants to the storm drain system include the following:

- Building Maintenance and Repair: FF-2
- Equipment Maintenance and Repair: FF-3
- Fueling: FF-4
- Material Storage, Handling, and Disposal: FF-7
- Spill Prevention and Control: FF-10
- Vehicle and Equipment Cleaning: FF-11
- Vehicle and Equipment Storage: FF-12
- Waste Disposal and Handling: FF-13

Fire station personnel are referred to various Fact Sheets listed above that describe pollution prevention and model procedures associated with these activities. Pertinent Fact Sheets are identified by number (e.g. FF-2) in the above list of activities.

## 5. Fire Hydrant and Fire Sprinkler Testing

Fire hydrant and fire sprinkler testing are normally performed by water utility or other non-fire fighting personnel. However, in the event that such activities are performed by fire fighting personnel, the model procedures contained within Fact Sheet FP-6 in Appendix A-5 and Fact Sheet IC-23 in Appendix A-9 of the Local Implementation Plan should be followed.

## 6. Trauma Scene Clean-up

Although fire fighting personnel are not routinely involved in the clean-up of trauma scenes, they may be incidentally involved while performing other work. Trauma scene clean-up must only be performed by OSHA – blood-borne pathogen trained personnel. Specific guidance on trauma scene clean-up procedures is provided in Section 10.2.9.1 of the DAMP.

## FP-7

Additional information and guidance for clean-up policies and procedures for bodily fluids may be obtained 24 hours a day by contacting the Orange County Health Care Agency (HCA) – Public Health by calling Orange County Control One at (714) 628-7008.

### REFERENCES:

*California Storm Water Best Management Practice Handbooks. Municipal Best Management Practice Handbooks. Prepared by Camp Dresser & McKee, Larry Walker Associates, Uribe and Associates, Resources Planning Associates for Stormwater Quality Task Force. March 1993.*

*California Storm Water Best Management Practice Handbooks. Industrial/Commercial and Municipal Best Management Practice Handbook. Prepared by Camp Dresser & McKee, Larry Walker Associates for California Stormwater Quality Association. January 2003.*



**DF-1**

## **DRAINAGE FACILITY OPERATION AND MAINTENANCE**

**As a consequence of its function, the stormwater conveyance system collects and transports urban runoff and storm water that may contain certain pollutants. Consequently these pollutants may accumulate in the system and must be removed periodically. In addition, the systems must also be maintained to function properly hydraulically to avoid flooding. Maintaining the system may involve the following activities:**

**Inspection and Cleaning of Stormwater Conveyance Structures**

**Controlling Illicit Connections and Discharges**

**Controlling Illegal Dumping**

### **MODEL PROCEDURES:**

#### **1. Inspection and Cleaning of Drainage Facilities**

##### **General Guidelines**

- ✓ Annually inspect and clean drainage facilities as needed. Maintain appropriate records. This information should be used to determine problem areas that may need to be checked more often.
- ✓ Remove trash and debris as needed from open channels and properly dispose of these materials (at an approved landfill or recycling facility). It should be noted that major debris removal may require other regulatory permits prior to completing the work.
- ✓ Conduct annual visual inspections during the dry season to determine if there are problem inlets where sediment/trash or other pollutants accumulate.
- ✓ Eliminate any discharges that may occur while maintaining and cleaning any municipal drainage facilities.
- ✓ Train crews in proper maintenance activities, including record keeping and disposal.
- ✓ Provide energy dissipaters (e.g. riprap) below culvert outfalls to minimize potential for erosion.

## Storm Drain Flushing

- ✓ Flushing of storm drains or storm drain inlets should only be done in emergencies.
- ✓ If flushed, the material should be collected (vacuumed), treated with an appropriate filtering device to remove sand and debris and disposed of properly.

## Waste Management

→ *Note: Permission must be obtained for any discharge of wash water to the sanitary sewer from the local sewerage agency.*

- ✓ Store wastes collected from cleaning activities of the drainage facilities in appropriate containers or temporary storage sites in a manner that prevents discharges to the storm drain.
- ✓ Dewater the wastes if necessary with outflow into the sanitary sewer if permitted. Water should be treated with an appropriate filtering device to remove the sand and debris prior to discharge to the sanitary sewer. If discharge to the sanitary sewer is not permitted, water should be pumped or vacuumed to a tank and properly disposed of. Do not dewater near a storm drain or stream.

### OPTIONAL:

- Provide for laboratory analysis of at least one randomly collected sediment (less the debris) sample per year from the storm drain inlet cleaning program to ensure that it does not meet the EPA criteria for hazardous waste. If the sample is determined to be hazardous, the sediment must be disposed of as hazardous waste.

## 2. Controlling Illicit Connections and Discharges

Improper physical connections to the storm drain system can occur in a number of ways, such as overflow cross-connects from sanitary sewers and floor drains from businesses like auto shops and restaurants. Illicit discharges and illegal connections can generally be detected and investigated through a combination of programs and approaches that target a variety of pollutants and sources.

- ✓ Report prohibited discharges such as dumping, paint spills, abandoned oil containers, etc. observed during the course of normal daily activities so they can be investigated, contained, and cleaned up.
- ✓ Conduct field investigations to detect and eliminate existing illicit connections and improper disposal of pollutants into the storm drain (i.e. identify problem areas where discharges or illegal connections may occur and follow up stream to determine the source(s)).
- ✓ Report all observed illicit connections and discharges to the City's 24-hour water pollution problem reporting hotline (714) 538-1961 or the countywide number at 1(877) 89-SPILL.
- ✓ Encourage public reporting of improper waste disposal by distributing public education materials and advertising the 24-hour water pollution problem reporting hotline.



## Storm Drain Stenciling



*Storm drain system signs act as highly visible source controls that are typically stenciled directly adjacent to storm drain inlets.*

- ✓ Stencil the storm drains

### OPTIONAL:

- Create a volunteer work force to stencil storm drain inlets; municipal staff must organize, market, and provide training to initiate the volunteer program:
  - Promote volunteer services through radio/television and mail-out campaigns.
  - Educate businesses and residents about storm water pollution, the storm drain system, and the watershed and provide information on alternatives such as recycling, household hazardous waste disposal, and safer products.

## 3. Controlling Illegal Dumping

Illegally dumped wastes can cause storm water and receiving water quality problems as well as clog the storm drain system itself. Non-hazardous solid wastes may include garbage, trash, refuse, paper, rubbish, ashes, industrial wastes, demolition and construction wastes, abandoned vehicles and parts thereof, discarded home and industrial appliances, manure, vegetable or animal solid and semi-solid wastes and other discarded solid or semi-solid waste provided that such wastes do not contain wastes which must be managed as hazardous wastes, or wastes which contain soluble pollutants in concentration which exceed applicable water quality objectives or could cause degradation of waters of the state.

### Field Investigation

- ✓ Report prohibited discharges such as dumpings observed during the course of normal daily activities so they can be investigated, contained and cleaned up.
- ✓ Conduct field investigations to detect and eliminate improper disposal of pollutants into the storm drain (i.e. identify problem areas where discharges or illegal connections may occur and follow up stream to determine the source(s)).
- ✓ Report all observed illicit connections and discharges to the City's 24-hour water pollution problem reporting hotline (714) 538-1961 or the countywide number at 1(877) 89-SPILL.
- ✓ Encourage public reporting of improper waste disposal by distributing public education materials and advertising the 24-hour water pollution problem reporting hotline.

### OPTIONAL:

- Post "No Dumping" signs in problem areas with a phone number for reporting dumping and disposal. Signs should also indicate fines and penalties for illegal dumping.

## **Training/Education/ Outreach**

- ✓ Annually train municipal employees to recognize and report illegal dumping.
- ✓ Encourage public reporting of illegal dumping by advertising the City's 24-hour water pollution problem reporting hotline (714) 538-1961 or the countywide number at 1(877) 89-SPILL.

### OPTIONAL:

- Educate the public with public education materials such as a hotline and/or door hanger (door hangers are placed on the front doors in neighborhoods where illegal dumping has occurred to inform the reader why illegal dumping is a problem, and that illegal dumping carries a significant financial penalty).
- Educate the public through volunteer water quality monitoring programs. Volunteers can be trained to notice and report the presence and suspected source of an observed pollutant to the appropriate public agency.

---

## **LIMITATIONS:**

Clean-up activities may create a slight disturbance for local aquatic species. Access to items and material on private property may be limited. Trade-offs may exist between channel hydraulics and water quality/riparian habitat. If storm channels or basins are recognized as wetlands, many activities, including maintenance, may be subject to regulation and permitting.

## **REFERENCES:**

California Storm Water Best Management Practice Handbooks. Municipal Best Management Practice Handbook. Prepared by Camp Dresser & McKee, Larry Walker Associates, Uribe and Associates, Resources Planning Associates for Stormwater Quality Task Force. March 1993.

Harvard University. 2002. Solid Waste Container Best Management Practices – Fact Sheet On-Line Resources – Environmental Health and Safety.

Model Urban Runoff Program: A How-To Guide for Developing Urban Runoff Programs for Small Municipalities. Prepared by City of Monterey, City of Santa Cruz, California Coastal Commission, Monterey Bay National Marine Sanctuary, Association of Monterey Bay Area Governments, Woodward-Clyde, Central Coast Regional Water Quality Control Board. July. 1998.

Santa Clara Valley Urban Runoff Pollution Prevention Program. 1997 Urban Runoff Management Plan. September 1997, updated October 2000.

Exhibit A-5.III

General Inspection Form  
Activity Specific Inspection Sheets

**EXHIBIT A-5.III**

**CITY OF ORANGE**  
**MUNICIPAL ACTIVITIES**  
**INSPECTION FORMS**

**Fixed Facilities**

- **General Inspection Form**
- **Activity Specific Inspection Forms**
  - **Building Maintenance and Repair**
  - **Equipment Maintenance and Repair**
  - **Fueling**
  - **Landscape Maintenance**
  - **Material Loading and Unloading**
  - **Material Storage, Handling and Disposal**
  - **Minor Construction**
  - **Parking Lot Maintenance**
  - **Spill Prevention and Control**
  - **Vehicle and Equipment Cleaning**
  - **Vehicles and Equipment Storage**
  - **Waste Handling and Disposal**

**Field Programs**

- **General Inspection Form**
- **Activity Specific Inspection Forms**
  - **Lake Management**
  - **Landscape Maintenance**
  - **Roads, Streets and Highway Operations and Maintenance**
  - **Sidewalk, Plaza and Fountain Maintenance and Cleaning**
  - **Solid Waste Handling**
  - **Water and Sewer Operation and Maintenance**

**Drainage Facilities**

- **General Inspection Form**
- **Activity Specific Inspection Forms**
- **Drainage Facility Operation and Maintenance**

# FIXED FACILITY GENERAL INSPECTION FORM

COVER SHEET (Required for all inspections)

<b>Inspection Performed by:</b> <b>Date:</b>	<b>Time of Inspection:</b> <b>Weather at Time of Inspection:</b>
<b>Fixed Facility Information</b>	
Name of Facility: Address:	Contact Name: Title: Phone Number:
Number of Employees at Facility:	Days of Operation per Week:
<b>Leased Facility Information</b>	
Is this Fixed Facility leased? Yes No <input type="checkbox"/> <input type="checkbox"/>	Lessor Contact Information: Contact Name: Title:
Is this a lessor self-inspection? Yes No <input type="checkbox"/> <input type="checkbox"/>	Company Name: Phone Number: Address:
<b>Type of Fixed Facility (choose one):</b>	
Municipal Waste Facilities <input type="checkbox"/> Municipal Landfill <input type="checkbox"/> Publicly Owned Treatment Works <input type="checkbox"/> Incinerator <input type="checkbox"/> Solid Waste Transfer Facility <input type="checkbox"/> Land Application Site <input type="checkbox"/> Site for Disposing/Treating Sewage Sludge <input type="checkbox"/> Hazardous Waste Treatment, Disposal Site <input type="checkbox"/> Sanitary Landfill	Other Owned/Operated Facilities <input type="checkbox"/> Municipal Air Field <input type="checkbox"/> Parks/Cemetery <input type="checkbox"/> Public Building (Police, Fire, Libraries) <input type="checkbox"/> Stadium <input type="checkbox"/> Stable <input type="checkbox"/> Boat/Shipping Yard <input type="checkbox"/> Animal Shelter/Services <input type="checkbox"/> Public Parking Facility <input type="checkbox"/> Other: _____
Corporation Yards <input type="checkbox"/> Corporate Yard <input type="checkbox"/> Maintenance Yard <input type="checkbox"/> Storage Yard for Materials	
<b>Identification of Activities That Occur at this Fixed Facility</b> (For each identified activity - complete the attached activity specific inspection form)	
<input type="checkbox"/> Building Maintenance and Repair <input type="checkbox"/> Parking Lot Maintenance <input type="checkbox"/> Landscape Maintenance <input type="checkbox"/> Waste Handling, Storage, Disposal <input type="checkbox"/> Material Handling, Storage, Disposal <input type="checkbox"/> Fueling	<input type="checkbox"/> Vehicle and Equipment Cleaning <input type="checkbox"/> Vehicle and Equipment Storage <input type="checkbox"/> Material Loading and Unloading <input type="checkbox"/> Minor Construction <input type="checkbox"/> Bay / Harbor Activities (Spill Prevention and Control is incorporated within other forms)
<b>Reason for Inspection:</b>	
<input type="checkbox"/> Routine (Annual) Inspection <input type="checkbox"/> Routine (Quarterly) Corporate Yard Inspection <input type="checkbox"/> Facility Moved/Changed	<input type="checkbox"/> First Inspection <input type="checkbox"/> Follow-up Inspection <input type="checkbox"/> Complaint Inspection <input type="checkbox"/> Other: _____
<b>Outcome of Inspection:</b>	
<input type="checkbox"/> Disciplinary Action <input type="checkbox"/> Verbal Warning <input type="checkbox"/> Written Warning <input type="checkbox"/> NOV - Notice of Violation	<input type="checkbox"/> No Corrective Action Necessary <input type="checkbox"/> Other: _____

**CITY OF ORANGE**

**ENVIRONMENTAL PERFORMANCE REPORT**

**Municipal Facilities and Field Programs**

**General Facility / Field Program Information (Mandatory)**

Check One:  Fixed Facility  Field Program

**Facility / Field Program Name:**

**Address (if applicable):**

**Contact Person / Title:**

**Number of Employees:**

No Previous or Current Problems Have Been Identified

**Actionable Issues From Previous Reporting Period: From To**

Past Problems Identified on Previous Corrective Actions sheet dated

If the corrective actions as identified in the previous report have not been completed an explanation and new estimated start and completion dates are provided on a separate sheet.

**Information From Current Reporting Period: From To**

How Many Inspections Have Occurred During the Reporting Period:

Dates of Inspection(s):

Current Problems/Issues Identified: see Corrective Actions sheet dated

**Actionable Issue Improvements**

**Actionable Issues From Current Inspection Form :**

Start Date Estimated Completion Date

**Current Corrective Action Plans:**

**Report Prepared By: (Mandatory)**

Signature: Date:

Printed Name and Title:

# ACTIVITY SPECIFIC INSPECTION FORM

## Bay / Harbor Activities

**Complete this form only if related activities are conducted at this Fixed Facility**

Question	Answer Yes/No	If Answered Yes, Suggested Corrective Action Plan (See Model Maintenance Procedures for further Suggested Corrective Action Plans)
<b><i>On Board and General Maintenance</i></b>		
If non-stormwater discharge occurs, can sediment, trash, or other materials potentially wash into storm drains or waterbodies?	<input type="checkbox"/> Yes  <input type="checkbox"/> No	<input type="checkbox"/> Sweep surfaces or use other dry methods to clean objects.
		<input type="checkbox"/> If water or liquids must be used, wash away from drainage facilities or water courses.
		<input type="checkbox"/> Place a barrier around perimeter of washing area (sandbags, silt fence).
		<input type="checkbox"/> Place sandbags around inlets, drainage facilities and water courses.
		<input type="checkbox"/> If a sprayer must be used, consider a high pressure sprayer.
		<input type="checkbox"/> Other:
Has fuel or other fluids entered waterbodies from leaks or spills within the last reporting period?	<input type="checkbox"/> Yes  <input type="checkbox"/> No	<input type="checkbox"/> Designate maintenance areas away from drainage systems and water courses.
		<input type="checkbox"/> Use extreme care when fueling adjacent to water.
		<input type="checkbox"/> Place a barrier around perimeter of maintenance area (sandbags, silt fence).
		<input type="checkbox"/> Place sandbags around inlets, drainage facilities and water courses.
		<input type="checkbox"/> Use absorbent materials on small spills rather than hosing down or burying the spill.
		<input type="checkbox"/> Remove absorbent materials promptly and dispose of properly.
		<input type="checkbox"/> Other:
<b><i>Disposal of Wastewater and Ballast Water</i></b>		
Is direct discharge of wastewater and ballast water occurring?	<input type="checkbox"/> Yes	<input type="checkbox"/> Properly dispose of such water in an approved marine sanitation devise (MSD)
	<input type="checkbox"/> No	<input type="checkbox"/> Other:
<b><i>Cleaning, Chipping, and Painting</i></b>		
Does discharge into a storm drain or waterbody occur when washing, chipping, or painting boats, piers, etc.?	<input type="checkbox"/> Yes  <input type="checkbox"/> No	<input type="checkbox"/> Perform activities away from drainage facilities or water courses.
		<input type="checkbox"/> Place a barrier around perimeter of activity (sandbags, silt fence).
		<input type="checkbox"/> If a hose is used, consider a high pressure sprayer.
		<input type="checkbox"/> Use environmentally friendly products.
		<input type="checkbox"/> Use dry methods to clean objects and surfaces.
		<input type="checkbox"/> Limit over hull maintenance to minor sanding and painting.
		<input type="checkbox"/> Conduct major hull resurfacing on land.
		<input type="checkbox"/> Do not mix paint or chemicas on docks.
		<input type="checkbox"/> Shelter blasting and painting with tarps.
		<input type="checkbox"/> Other:

**If Answering "Yes" to any of the above questions refer to "Suggested Corrective Action Plan".**

# ACTIVITY SPECIFIC INSPECTION FORM

## Building Maintenance and Repair

**Complete this form only if related activities are conducted at this Fixed Facility**

Question	Answer Yes/No	If Answered Yes, Suggested Corrective Action Plan (See Model Maintenance Procedures for further Suggested Corrective Action Plans)
----------	------------------	---

### ***Building Maintenance***

When using liquids to repair roofs, do small particles in the gutter have the potential to leave the jobsite?	<input type="checkbox"/> Yes  <input type="checkbox"/> No	<input type="checkbox"/> Wash the gutter and place geofabric over gutter outlet.
		<input type="checkbox"/> Sweep gutter and dispose of particles properly.
		<input type="checkbox"/> If the downspout is tight lined, place a temporary plug at first available point and pump out water with vacor truck. Clean inlet where plug was placed.
		<input type="checkbox"/> Other:
Do exterior painting activities contribute liquids or other materials to storm drains?	<input type="checkbox"/> Yes  <input type="checkbox"/> No	<input type="checkbox"/> Mix paint and liquids indoors or in a containment area.
		<input type="checkbox"/> Use recycled and less hazardous products when possible.
		<input type="checkbox"/> Perform activities away from drainage facilities or water courses.
		<input type="checkbox"/> Place a barrier around perimeter of activity (sandbags, silt fence).
		<input type="checkbox"/> Place sandbags around inlets, drainage facilities and water courses.
		<input type="checkbox"/> Other:

### ***Material Storage***

Do maintenance and repair materials have the potential to travel beyond the property?	<input type="checkbox"/> Yes  <input type="checkbox"/> No	<input type="checkbox"/> Store materials in a covered area.
		<input type="checkbox"/> Place a barrier around perimeter of the storage area (sandbags, silt fence).
		<input type="checkbox"/> Other:

### ***Building Cleaning***

Do exterior cleaning activities such as window cleaning have the potential to travel behind the property?	<input type="checkbox"/> Yes  <input type="checkbox"/> No	<input type="checkbox"/> Use the minimum amount of water and/or detergent possible.
		<input type="checkbox"/> Use recycled, biodegradable and less hazardous products when possible.
		<input type="checkbox"/> Perform activities away from drainage facilities or water courses.
		<input type="checkbox"/> Dry surface as soon as possible (sponge or blower).
		<input type="checkbox"/> Other:

### ***Graffiti Cleaning***

Are graffiti abatement activities performed during rain events?	<input type="checkbox"/> Yes  <input type="checkbox"/> No	<input type="checkbox"/> Postpone cleaning activities until after rain event.
		<input type="checkbox"/> Other:
Does graffiti cleaning require wash water that may carry pollutants?	<input type="checkbox"/> Yes  <input type="checkbox"/> No	<input type="checkbox"/> Plug nearby storm drains and vacuum/pump wash water to sanitary sewer.
		<input type="checkbox"/> Other:

### ***Painting***

Does cleaning of paint brushes, etc. occur in the street, gutter, or near a storm drain?	<input type="checkbox"/> Yes  <input type="checkbox"/> No	<input type="checkbox"/> Rinse paint brushes, etc. in sink connected to a sanitary sewer system.
		<input type="checkbox"/> Never clean brushes, etc. in the street, gutter, or near a storm drain
		<input type="checkbox"/> Other:



<b>Miscellaneous</b>		
Do any other non-stormwater discharges occur, such as floor washing, water leakage from equipment/vehicles, or possible illicit connections?	<input type="checkbox"/> Yes <input type="checkbox"/> No	<input type="checkbox"/> Perform activity away from drainage facilities or water courses.
		<input type="checkbox"/> Place sandbags around inlets, drainage facilities and water courses.
		<input type="checkbox"/> Use less water during activity.
		<input type="checkbox"/> Divert wash water into a treatment basin.
		<input type="checkbox"/> Other:
Does this Fixed Facility have an inadequate spill prevention and containment plan?	<input type="checkbox"/> Yes <input type="checkbox"/> No	<input type="checkbox"/> Develop a comprehensive spill prevention plan.
		<input type="checkbox"/> Use absorbent materials on small spills rather than hosing down or burying the spill.
		<input type="checkbox"/> Remove absorbent materials promptly and dispose of properly.
		<input type="checkbox"/> Stock appropriate clean-up materials.
		<input type="checkbox"/> Other:

**If Answering "Yes" to any of the above questions refer to "Suggested Corrective Action Plan".**

# ACTIVITY SPECIFIC INSPECTION FORM

## Equipment Maintenance and Repair

**Complete this form only if related activities are conducted at this Fixed Facility**

Question	Answer Yes/No	If Answered Yes, Suggested Corrective Action Plan (See Model Maintenance Procedures for further Suggested Corrective Action Plans)
<b><i>General Maintenance and Repair</i></b>		
Are vehicles and/or equipment stored in an uncovered area?	<input type="checkbox"/> Yes  <input type="checkbox"/> No	<input type="checkbox"/> Store vehicles and equipment in covered areas.
		<input type="checkbox"/> If covered areas for storage are unavailable, inspect storage areas frequently for leaks and damage.
		<input type="checkbox"/> Store vehicles and equipment away from drainage systems and waterbodies.
		<input type="checkbox"/> Other:
<b><i>Vehicle and Machine Repair</i></b>		
Do vehicles and/or equipment leak oil, or any other fluids?	<input type="checkbox"/> Yes <input type="checkbox"/> No	<input type="checkbox"/> Use absorbent materials on small leaks rather than hosing down or burying. Remove absorbent materials promptly and dispose of properly.
		<input type="checkbox"/> Use drip pan underneath equipment/vehicle.
		<input type="checkbox"/> Stock appropriate clean-up materials.
		<input type="checkbox"/> Inspect vehicles and equipment frequently for leaks.
<input type="checkbox"/> Other:		
Is vehicle and/or equipment repair/maintenance performed near a drain not connected to the sanitary sewer system?	<input type="checkbox"/> Yes <input type="checkbox"/> No	<input type="checkbox"/> Designate maintenance areas away from drainage systems and water courses.
		<input type="checkbox"/> Protect maintenance areas by placing a barrier around perimeter.
		<input type="checkbox"/> Consider using portable tents or covers over maintenance areas.
		<input type="checkbox"/> Do not dispose oil in dumpster, storm drain or waterbody.
<input type="checkbox"/> Other:		
<b><i>Waste Handling/Disposal</i></b>		
Do non-stormwater discharges occur, such as shop floor washing, or water leakage from equipment?	<input type="checkbox"/> Yes  <input type="checkbox"/> No	<input type="checkbox"/> Store equipment away from drainage facilities or water courses.
		<input type="checkbox"/> Place sandbags around inlets, drainage facilities and water courses.
		<input type="checkbox"/> Clean area with mechanical sweeper, rather than hosing.
		<input type="checkbox"/> Contain water and haul for treatment.
<input type="checkbox"/> Other:		

**If Answering "Yes" to any of the above questions refer to "Suggested Corrective Action Plan".**

# ACTIVITY SPECIFIC INSPECTION FORM

## Fueling

**Complete this form only if related activities are conducted at this Fixed Facility**

Question	Answer Yes/No	If Answered Yes, Suggested Corrective Action Plan (See Model Maintenance Procedures for further Suggested Corrective Action Plans)
Can fueling activities impact area storm drains?	<input type="checkbox"/> Yes  <input type="checkbox"/> No	<input type="checkbox"/> Designate a fueling area away from drainage facilities and water courses.
		<input type="checkbox"/> Protect fueling areas by placing a barrier around perimeter.
		<input type="checkbox"/> Use drain pans or drop cloths to catch spills or leaks while fueling.
		<input type="checkbox"/> Do not top-off fuel tanks.
		<input type="checkbox"/> Other:
Can overflow occur when fueling vehicles and/or equipment on-site?	<input type="checkbox"/> Yes  <input type="checkbox"/> No	<input type="checkbox"/> Designate a fueling area away from drainage facilities and water courses.
		<input type="checkbox"/> Protect fueling areas by placing a barrier around perimeter.
		<input type="checkbox"/> Use drain pans or drop cloths to catch spills or leaks while fueling.
		<input type="checkbox"/> Do not top-off fuel tanks.
		<input type="checkbox"/> Use absorbent materials to clean-up spills rather than hosing down or burying.
Can stormwater run on to fueling areas?	<input type="checkbox"/> Yes  <input type="checkbox"/> No	<input type="checkbox"/> Designate a fueling area away from drainage facilities and water courses.
		Protect fueling areas by placing a barrier around perimeter.
		<input type="checkbox"/> Use drain pans or drop cloths to catch spills or leaks while fueling.
		<input type="checkbox"/> Do not top-off fuel tanks.
		Use absorbent materials to clean-up spills rather than hosing down or burying.
Is the fueling area uncovered?	<input type="checkbox"/> Yes  <input type="checkbox"/> No	<input type="checkbox"/> Place a canopy over fueling area.
		<input type="checkbox"/> Other:
		<input type="checkbox"/> Other:

**If Answering "Yes" to any of the above questions refer to "Suggested Corrective Action Plan".**

# ACTIVITY SPECIFIC INSPECTION FORM

<b>Landscape Maintenance</b>		
<b>Complete this form only if related activities are conducted at this Fixed Facility</b>		
Question	Answer Yes/No	If Answered Yes, Suggested Corrective Action Plan (See Model maintenance Procedures for further Suggested Corrective Action Plans)
<b><i>Mowing, Trimming/Weeding and Planting</i></b>		
Do green waste trimmings or clippings enter storm drains, gutters, or travel off site?	<input type="checkbox"/> Yes <input type="checkbox"/> No	<input type="checkbox"/> Perform landscaping activities away from drainage facilities or water courses. <input type="checkbox"/> Place a barrier around perimeter of landscape activity area (sandbags, silt fence). <input type="checkbox"/> Install baggage for clippings on mowers. <input type="checkbox"/> Train staff to improve dry clean-up of green waste from gutters and drain systems. <input type="checkbox"/> Other:
<b><i>Irrigation</i></b>		
Does excess irrigation runoff have the potential to carry pollutants into the stormdrain?	<input type="checkbox"/> Yes <input type="checkbox"/> No	<input type="checkbox"/> Berm the irrigation area to prevent run-on and runoff. <input type="checkbox"/> Place sandbags around inlets, drainage facilities and water courses. <input type="checkbox"/> Ensure sprinklers are spraying appropriately. <input type="checkbox"/> Reduce the amount of water being applied or modify sprinkler heads to spray more efficiently. <input type="checkbox"/> Other:
<b><i>Fertilizer and Pesticide Management</i></b>		
Are fertilizers and pesticides mixed or prepared near a storm drain?	<input type="checkbox"/> Yes <input type="checkbox"/> No	<input type="checkbox"/> Mix and prepare fertilizers and pesticides away from storm drains. <input type="checkbox"/> Use the minimal amount of fertilizers and pesticides. <input type="checkbox"/> Other:
Are fertilizers and pesticides spilled accidentally or discarded onto the surface?	<input type="checkbox"/> Yes <input type="checkbox"/> No	<input type="checkbox"/> Work fertilizers and pesticides into the soil rather than dumping. <input type="checkbox"/> Other:
Are fertilizers and pesticides over applied?	<input type="checkbox"/> Yes <input type="checkbox"/> No	<input type="checkbox"/> Train staff to use proper fertilizer and pesticide application procedures. <input type="checkbox"/> Use the minimal amount of fertilizers and pesticides. <input type="checkbox"/> Other:
Are fertilizers and pesticides applied when there is a 25% or more chance of rain?	<input type="checkbox"/> Yes <input type="checkbox"/> No	<input type="checkbox"/> Apply fertilizers and pesticides when there is a 75% or more chance of no rain. <input type="checkbox"/> Other:
Are more fertilizers and pesticides stored on site than needed?	<input type="checkbox"/> Yes <input type="checkbox"/> No	<input type="checkbox"/> Only purchase and store what is needed. <input type="checkbox"/> Other:
Have fertilizers and pesticides been disposed of improperly?	<input type="checkbox"/> Yes <input type="checkbox"/> No	<input type="checkbox"/> Rinse containers with fertilizer/pesticide and use rinse as product. Dispose of unused fertilizer/pesticide as hazardous waste. <input type="checkbox"/> Other:
<b><i>Managing Landscape Waste</i></b>		
Are compost leaves, sticks, or other collected vegetation disposed near a waterway or storm drain system?	<input type="checkbox"/> Yes <input type="checkbox"/> No	<input type="checkbox"/> Dispose of materials at a permitted landfill <input type="checkbox"/> Place vegetation piles away from drainage facilities or water courses. <input type="checkbox"/> Install baggage for clippings on mowers. <input type="checkbox"/> Train staff to improve dry clean-up of green waste from gutters and drain systems. <input type="checkbox"/> Other:
<b><i>Erosion Control</i></b>		
Is discing used as a means of vegetative management?	<input type="checkbox"/> Yes <input type="checkbox"/> No	<input type="checkbox"/> Use other methods for vegetative management. <input type="checkbox"/> Train staff to improve erosion control on-site. <input type="checkbox"/> Other:

## ACTIVITY SPECIFIC INSPECTION FORM

<b>Material Loading and Unloading</b>		
<b>Complete this form only if related activities are conducted at this Fixed Facility</b>		
Question	Answer Yes/No	If Answered Yes, Suggested Corrective Action Plan (See Model Maintenance Procedures for further Suggested Corrective Action Plans)
Is debris present around the loading / unloading area that has the potential to enter storm drains or drainage facilities?	<input type="checkbox"/> Yes  <input type="checkbox"/> No	<input type="checkbox"/> Regularly clean work areas to remove materials. <input type="checkbox"/> Avoid loading or exposing materials during rain events. <input type="checkbox"/> Direct stormwater to minimize contact with waste materials. <input type="checkbox"/> Load / unload only during dry weather. <input type="checkbox"/> Other:
Can handled materials come into contact with stormwater?	<input type="checkbox"/> Yes  <input type="checkbox"/> No	<input type="checkbox"/> Designate storage areas away from drainage system or water course. <input type="checkbox"/> Load / unload in covered or enclosed areas. <input type="checkbox"/> Direct stormwater with sloping pavement to minimize contact with waste materials. <input type="checkbox"/> Pave area where transfers occur. <input type="checkbox"/> Place a barrier around perimeter of loading/unloading area. <input type="checkbox"/> Load / unload only during dry weather. <input type="checkbox"/> Other:
Does the Fixed Facility have an inadequate spill prevention and cleanup program?	<input type="checkbox"/> Yes  <input type="checkbox"/> No	<input type="checkbox"/> Develop a emergency spill cleanup plan. <input type="checkbox"/> Use drip pans or comparable devices during transfers. <input type="checkbox"/> Remove absorbent materials promptly and dispose of properly. <input type="checkbox"/> Place spill kits near the loading / unloading area. <input type="checkbox"/> Stock appropriate clean-up materials. <input type="checkbox"/> Know who to contact if large or hazardous spills occur. <input type="checkbox"/> Other:
Are staff unaware of their roles and responsibilities during spills (with emphasis on new employees)?	<input type="checkbox"/> Yes  <input type="checkbox"/> No	<input type="checkbox"/> Properly train forklift operators. <input type="checkbox"/> Determine roles and responsibilities of employees and supervisors and train accordingly. <input type="checkbox"/> Provide "refreshers" training for existing employees. <input type="checkbox"/> Train new employees. <input type="checkbox"/> Develop procedures for loading and unloading. <input type="checkbox"/> Other:

**If Answering "Yes" to any of the above questions refer to "Suggested Corrective Action Plan".**

# ACTIVITY SPECIFIC INSPECTION FORM

## Material Storage, Handling, and Disposal

**Complete this form only if related activities are conducted at this Fixed Facility**

Question	Answer Yes/No	If Answered Yes, Suggested Corrective Action Plan (See Model Maintenance Procedures for further Suggested Corrective Action Plans)
<b><i>General Material Storage, Handling, and Disposal</i></b>		
Can stored materials come in contact with stormwater?	<input type="checkbox"/> Yes  <input type="checkbox"/> No	<input type="checkbox"/> Designate secured storage areas away from storm drain system and water courses.
		<input type="checkbox"/> Store materials indoors if possible, or cover with a roof.
		<input type="checkbox"/> Inspect storage areas before and after rainfall events, and at least weekly all other times.
		<input type="checkbox"/> If materials are stockpiled, place a barrier around perimeter (berm, sandbags, silt fence).
		<input type="checkbox"/> Place sandbags around inlets, drainage facilities and water courses.
		<input type="checkbox"/> Keep an accurate and up-to-date inventory of materials delivered and stored on-site.
		<input type="checkbox"/> Place plastic cover over stored material, especially those treated with amendments.
		<input type="checkbox"/> Train employees in proper storage measures.
		<input type="checkbox"/> Minimize the amount of material stored on-site.
		<input type="checkbox"/> Other:
Are materials able to escape containment and litter or run off the Fixed Facility?	<input type="checkbox"/> Yes  <input type="checkbox"/> No	<input type="checkbox"/> Inspect storage areas before and after rainfall events, and at least weekly all other times.
		<input type="checkbox"/> If materials are stockpiled, place a barrier around perimeter (berms, sandbags, silt fence).
		<input type="checkbox"/> Place plastic cover over stored material.
		<input type="checkbox"/> Place sandbags around inlets, drainage facilities and water courses.
		<input type="checkbox"/> Store materials in a shed.
		<input type="checkbox"/> Store liquids in a designated area on an impervious surface within secondary containment.
		<input type="checkbox"/> Slope the area inside a curb to a drain with appropriate best management practice in place to treat waste.
<input type="checkbox"/> Other:		
Is debris allowed to litter the work site, enter storm drains, or travel beyond the site?	<input type="checkbox"/> Yes  <input type="checkbox"/> No	<input type="checkbox"/> Designate storage areas away from storm drain system and water courses.
		<input type="checkbox"/> If material is stockpiled, place a barrier around perimeter (sandbags, silt fence).
		<input type="checkbox"/> Sweep parking lots or other surfaces near storage areas regularly.
		<input type="checkbox"/> Place sandbags around inlets, drainage facilities and water courses.
		<input type="checkbox"/> Store materials in a shed.
		<input type="checkbox"/> Minimize the amount of material stored on-site.
<input type="checkbox"/> Other:		

Have any spills occurred within the last year at the material storage area(s) that contributed pollutants to stormwater?	<input type="checkbox"/> Yes <input type="checkbox"/> No	<input type="checkbox"/> Develop a spill prevention plan.
		<input type="checkbox"/> Inspect storage areas regularly for leaks or spills.
		<input type="checkbox"/> Inspect waste containers routinely for structural damage and repair or replace damaged containers as needed.
		<input type="checkbox"/> Check for leaks or spills during material loading and unloading.
		<input type="checkbox"/> Use absorbent materials on small spills rather than hosing down or burying the spill.
		<input type="checkbox"/> Remove absorbent materials promptly and dispose of properly.
		<input type="checkbox"/> If a large spill occurs, notify manager immediately and contain spread of spill.
		<input type="checkbox"/> Stock appropriate clean-up materials.
<input type="checkbox"/> Other:		

***Chemical Material Handling and Disposal***

Are chemical materials being stored improperly without safeguards against accidental spills?	<input type="checkbox"/> Yes <input type="checkbox"/> No	<input type="checkbox"/> Place materials in secondary containers.
		<input type="checkbox"/> Designate covered areas with impervious surfaces for chemical storage.
		<input type="checkbox"/> Keep chemicals in original well-labeled containers.
		<input type="checkbox"/> Store materials in covered dumpsters or waste containers with secure lids.
		<input type="checkbox"/> Surround liquid material containers with a curb or dike.
		<input type="checkbox"/> Install overflow protection devices.
		<input type="checkbox"/> Post restricted access warnings.
		<input type="checkbox"/> Other:

***Hazardous Material Handling***

Are staff unaware of their roles and responsibilities for hazardous waste handling or during a hazardous waste spill?	<input type="checkbox"/> Yes <input type="checkbox"/> No	<input type="checkbox"/> Contact the local HAZMAT office or Fire Department for hazardous waste labeling regulations.
		<input type="checkbox"/> Develop hazardous waste storage and handling procedures.
		<input type="checkbox"/> Develop spill prevention control and countermeasure and emergency preparedness plans.
		<input type="checkbox"/> Determine roles and responsibilities of employees and supervisors.
		<input type="checkbox"/> Designate authorized hazardous waste collection areas on-site.
		<input type="checkbox"/> Obtain permit for hazardous waste storage for more than 90 days.
		<input type="checkbox"/> Minimize the amount of hazardous material stored on-site.
		<input type="checkbox"/> Other:

**If Answering "Yes" to any of the above questions refer to "Suggested Corrective Action Plan".**

# ACTIVITY SPECIFIC INSPECTION FORM

<b>Minor Construction</b>		
<b>Complete this form only if related activities are conducted at this Fixed Facility</b>		
Question	Answer Yes/No	If Answered Yes, Suggested Corrective Action Plan (See Model Maintenance Procedures for further Suggested Corrective Action Plans)
<b>General Construction</b>		
Is uncontrolled construction debris present on site, or can debris escape from the site?	<input type="checkbox"/> Yes <input type="checkbox"/> No	<input type="checkbox"/> Prevent debris from entering storm drains. <input type="checkbox"/> Do not rinse or wash materials into gutters or storm drains. <input type="checkbox"/> Place sandbags around inlets, drainage facilities, and water courses. <input type="checkbox"/> Use prompt, dry clean-up methods. <input type="checkbox"/> Other:
Is water used for construction or dust control purposes?	<input type="checkbox"/> Yes <input type="checkbox"/> No	<input type="checkbox"/> Use water without causing non-stormwater discharge. <input type="checkbox"/> Protect drain inlets where necessary. <input type="checkbox"/> Use appropriate amount of water to provide dust control without causing a discharge. <input type="checkbox"/> Other:
Have spills occurred at the construction site within the last reporting period?	<input type="checkbox"/> Yes <input type="checkbox"/> No	<input type="checkbox"/> Develop a spill prevention plan. <input type="checkbox"/> Use absorbent materials on small spills rather than hosing down or burying the spill. <input type="checkbox"/> Remove absorbent materials promptly and dispose of properly. <input type="checkbox"/> If large spill occurs, notify manager immediately and contain spread of spill. <input type="checkbox"/> Stock appropriate clean-up materials. <input type="checkbox"/> Other:
Do non-stormwater discharges occur from on-site construction activities?	<input type="checkbox"/> Yes <input type="checkbox"/> No	<input type="checkbox"/> Perform activity away from drainage facilities or water courses. <input type="checkbox"/> Place sandbags around inlets, drainage facilities and water courses. <input type="checkbox"/> Use less water during activity. <input type="checkbox"/> Collect water and haul for treatment. <input type="checkbox"/> Other:
Is staff unaware of who to notify when potentially hazardous spills occur? Is staff unaware of their roles during a hazardous spill?	<input type="checkbox"/> Yes <input type="checkbox"/> No	<input type="checkbox"/> Contact the local HAZMAT office and ask who should be contacted in case of a hazardous spill. <input type="checkbox"/> Develop a spill prevention plan. <input type="checkbox"/> Designate and Haz-Mat certify employee(s). <input type="checkbox"/> Determine roles and responsibilities of employees and supervisors. <input type="checkbox"/> Other:



<b>Interim Material Storage</b>		
Can stormwater run through or directly contact stored materials and carry pollutants into drainage ways?	<input type="checkbox"/> Yes <input type="checkbox"/> No	<input type="checkbox"/> Designate storage areas away from drainage system or water course.
		<input type="checkbox"/> Place a barrier around perimeter of storage area (sandbags, silt fence).
		<input type="checkbox"/> Place plastic cover over stored waste.
		<input type="checkbox"/> Promptly remove and properly dispose waste materials.
		<input type="checkbox"/> Inspect storage areas before and after rainfall events, and at least weekly all other times.
		<input type="checkbox"/> Place sandbags around inlets, drainage facilities, and water courses.
		<input type="checkbox"/> Store hazardous waste materials on pallets or in secondary containment.
		<input type="checkbox"/> Minimize the amount of waste stored on-site.
<b>Concrete Work</b>		
Do materials from concrete work have the potential to enter storm drains?	<input type="checkbox"/> Yes <input type="checkbox"/> No	<input type="checkbox"/> Prevent debris from entering storm drains.
		<input type="checkbox"/> Do not rinse or wash materials into gutters or storm drains.
		<input type="checkbox"/> Designate and properly maintain a wash-out area.
		<input type="checkbox"/> Place sandbags around inlets, drainage facilities, and water courses.
Can saw cutting result in non-stormwater discharges?	<input type="checkbox"/> Yes <input type="checkbox"/> No	<input type="checkbox"/> Other:
		<input type="checkbox"/> Use as little water during saw cutting as possible.
		<input type="checkbox"/> Place sandbags around inlets, drainage facilities, and water courses.
Does truck wash-out have the potential to enter storm drains?	<input type="checkbox"/> Yes <input type="checkbox"/> No	<input type="checkbox"/> Other:
		<input type="checkbox"/> Establish an on site wash-out area.
		<input type="checkbox"/> Place sandbags around inlets, drainage facilities, and water courses.
		<input type="checkbox"/> Properly maintain wash-out area.
<b>Building Work</b>		
Can demolition debris travel off-site or enter storm drains?	<input type="checkbox"/> Yes <input type="checkbox"/> No	<input type="checkbox"/> Prevent debris from entering storm drains.
		<input type="checkbox"/> Do not rinse or wash materials into gutters or storm drains.
		<input type="checkbox"/> Place sandbags around inlets, drainage facilities, and water courses.
		<input type="checkbox"/> Use prompt, dry clean-up methods.
		<input type="checkbox"/> Cover debris to extent practicable.
		<input type="checkbox"/> Other:

**If Answering "Yes" to any of the above questions refer to "Suggested Corrective Action Plan".**

## ACTIVITY SPECIFIC INSPECTION FORM

<b>Parking Lot Maintenance</b>		
<b>Complete this form only if related activities are conducted at this Fixed Facility</b>		
Question	Answer Yes/No	If Answered Yes, Suggested Corrective Action Plan (See Model Maintenance Procedures for further Suggested Corrective Action Plans)
<b><i>Sweeping and Cleaning</i></b>		
Are storm drain inlets or catch basins in need of maintenance and/or cleaning?	<input type="checkbox"/> Yes <input type="checkbox"/> No	<input type="checkbox"/> Inspect, maintain, and/or clean storm drain inlets as required. <input type="checkbox"/> Other:
Can sediment, trash, or other materials potentially enter a storm drain during parking lot sweeping?	<input type="checkbox"/> Yes <input type="checkbox"/> No	<input type="checkbox"/> Place sandbags around inlets, drainage facilities and water courses. <input type="checkbox"/> Train contractors to avoid discharge into drainage facilities. <input type="checkbox"/> Use the most advanced equipment to perform lot sweeping. <input type="checkbox"/> Other:
Is the parking lot cleaned by using water?	<input type="checkbox"/> Yes <input type="checkbox"/> No	Use dry cleaning methods such as a street sweeper instead. <input type="checkbox"/> Perform hosing/washing away from drainage facilities or water courses. <input type="checkbox"/> Place a barrier around perimeter of area (sandbags, etc). Vacuum water and dispose of properly. <input type="checkbox"/> Use cold water, not hot. <input type="checkbox"/> Minimize containment area by only cleaning spot areas with water as needed and then dispose of properly. <input type="checkbox"/> Other:
Can litter potentially enter storm drains, or travel off of the property?	<input type="checkbox"/> Yes <input type="checkbox"/> No	<input type="checkbox"/> Provide waste containers in convenient places for employees and the public. <input type="checkbox"/> Use enclosed trash containers to limit contact with wind and rain. <input type="checkbox"/> Place trash containers away from inlets, drainage facilities and water courses. <input type="checkbox"/> Other:
<b><i>Surface Repair</i></b>		
Are any materials prepared or transferred near storm drain inlets?	<input type="checkbox"/> Yes <input type="checkbox"/> No	<input type="checkbox"/> Perform these activities away from storm drain inlets. <input type="checkbox"/> Cover storm drain inlets during repair. <input type="checkbox"/> Other:
Are concrete, asphalt or seal coating activities performed during wet weather?	<input type="checkbox"/> Yes <input type="checkbox"/> No	<input type="checkbox"/> Perform these activities during dry weather. <input type="checkbox"/> Other:
<b><i>Control Spills</i></b>		
Do spills remain on facility soils?	<input type="checkbox"/> Yes <input type="checkbox"/> No	<input type="checkbox"/> Always excavate and remove contaminated soil. <input type="checkbox"/> Other:
Are spilled materials and absorbents ever been disposed of improperly?	<input type="checkbox"/> Yes <input type="checkbox"/> No	<input type="checkbox"/> Dispose of spill material and absorbent pads in proper location and in accordance with Haz-Waste regulations if applicable. <input type="checkbox"/> Other:

**If Answering "Yes" to any of the above questions refer to "Suggested Corrective Action Plan".**

# ACTIVITY SPECIFIC INSPECTION FORM

## Spill Prevention and Control

**Complete this form only if related activities are conducted at this Fixed Facility**

Question	Answer Yes/No	If Answered Yes, Suggested Corrective Action Plan (See Model Maintenance Procedures for further Suggested Corrective Action Plans)
<b>Preparation and Prevention</b>		
Are chemical materials being stored improperly without safeguards against accidental spills?	<input type="checkbox"/> Yes <input type="checkbox"/> No	<input type="checkbox"/> Place materials in secondary containers.
		<input type="checkbox"/> Designate covered areas with impervious surfaces for chemical storage.
		<input type="checkbox"/> Keep chemicals in original well-labeled containers.
		<input type="checkbox"/> Store materials in covered dumpsters or waste containers with secure lids.
		<input type="checkbox"/> Surround liquid material containers with a curb or dike.
		<input type="checkbox"/> Install overflow protection devices.
		<input type="checkbox"/> Post restricted access warnings.
Does the Fixed Facility lack a spill prevention program?	<input type="checkbox"/> Yes <input type="checkbox"/> No	<input type="checkbox"/> Other:
		<input type="checkbox"/> Identify staff members responsible for developing a spill prevention program.
		<input type="checkbox"/> Research other Fixed Facilities with spill prevention programs and use as a guideline.
		<input type="checkbox"/> Know who to contact if large or hazardous spills occur.
<b>Spill Response</b>	<input type="checkbox"/> Yes <input type="checkbox"/> No	<input type="checkbox"/> Other:
		<input type="checkbox"/> Develop a spill prevention plan.
		<input type="checkbox"/> Inspect storage areas regularly for leaks or spills.
		<input type="checkbox"/> Inspect waste containers routinely for structural damage and repair or replace damaged containers as needed.
		<input type="checkbox"/> Check for leaks or spills during material loading and unloading.
		<input type="checkbox"/> Use absorbent materials on small spills rather than hosing down or burying the spill.
		<input type="checkbox"/> Remove absorbent materials promptly and dispose of properly.
Have any spills occurred within the last year in th area(s) that contributed pollutants to stormwater?	<input type="checkbox"/> Yes <input type="checkbox"/> No	<input type="checkbox"/> If a large spill occurs, notify manager immediately and contain spread of spill.
		<input type="checkbox"/> Stock appropriate clean-up materials.
		<input type="checkbox"/> Other:
		<input type="checkbox"/> Develop a spill prevention plan.
		<input type="checkbox"/> Inspect storage areas regularly for leaks or spills.
		<input type="checkbox"/> Inspect waste containers routinely for structural damage and repair or replace damaged containers as needed.
		<input type="checkbox"/> Check for leaks or spills during material loading and unloading.
<b>Reporting and Training</b>	<input type="checkbox"/> Yes <input type="checkbox"/> No	<input type="checkbox"/> Use absorbent materials on small spills rather than hosing down or burying the spill.
		<input type="checkbox"/> Remove absorbent materials promptly and dispose of properly.
		<input type="checkbox"/> If a large spill occurs, notify manager immediately and contain spread of spill.
		<input type="checkbox"/> Stock appropriate clean-up materials.
		<input type="checkbox"/> Other:
		<input type="checkbox"/> Contact the local HAZMAT office or Fire Department for hazardous waste labeling regulations.
		<input type="checkbox"/> Develop hazardous waste storage and handling procedures.
Are staff unaware of their roles and responsibilities for hazardous waste handling or during a hazardous waste spill?	<input type="checkbox"/> Yes <input type="checkbox"/> No	<input type="checkbox"/> Develop spill prevention control and countermeasure and emergency preparedness plans.
		<input type="checkbox"/> Determine roles and responsibilities of employees and supervisors.
		<input type="checkbox"/> Designate authorized hazardous waste collection areas on-site.
		<input type="checkbox"/> Obtain permit for hazardous waste storage for more than 90 days.
		<input type="checkbox"/> Minimize the amount of hazardous material stored on-site.
		<input type="checkbox"/> Other:
		<input type="checkbox"/> Develop hazardous waste storage and handling procedures.

If Answering "Yes" to any of the above questions refer to "Suggested Corrective Action Plan"

## ACTIVITY SPECIFIC INSPECTION FORM

<b>Vehicle and Equipment Cleaning</b>		
<b>Complete this form only if related activities are conducted at this Fixed Facility</b>		
Question	Answer Yes/No	If Answered Yes, Suggested Corrective Action Plan (See Model Maintenance Procedures for further Suggested Corrective Action Plans)
If vehicle and/or equipment washing takes place, does wash water enter an on site storm drain?	<input type="checkbox"/> Yes <input type="checkbox"/> No	<input type="checkbox"/> Wash away from drainage facilities or water courses. <input type="checkbox"/> Berm the wash area to prevent run-on and runoff. <input type="checkbox"/> Discharge wash water to sanitary sewer. <input type="checkbox"/> Use less water, consider a high pressure sprayer. <input type="checkbox"/> Construct a wash rack for the washing area. <input type="checkbox"/> Do not use solvents to clean. <input type="checkbox"/> Other:
If vehicle and/or equipment washing takes place, does the wash water run off-site?	<input type="checkbox"/> Yes <input type="checkbox"/> No	<input type="checkbox"/> Construct a wash rack for the washing area. <input type="checkbox"/> Berm the wash area to prevent run-on and runoff. <input type="checkbox"/> Discharge wash water to sanitary sewer. <input type="checkbox"/> Divert wash water to a treatment basin. <input type="checkbox"/> Other:
Does steam cleaning or engine degreasing take place on-site that has the potential to affect stormwater quality?	<input type="checkbox"/> Yes <input type="checkbox"/> No	<input type="checkbox"/> Perform steam cleaning and engine degreasing at a more appropriate location, off-site. <input type="checkbox"/> Berm the wash area to prevent run-on and runoff. <input type="checkbox"/> Discharge wash water to sanitary sewer. <input type="checkbox"/> Divert wash water to a treatment basin. <input type="checkbox"/> Other:
Is a mobile washer used that results in wash water runoff?	<input type="checkbox"/> Yes <input type="checkbox"/> No	<input type="checkbox"/> Construct a wash rack for the washing area. <input type="checkbox"/> Berm the wash area to prevent run-on and runoff. <input type="checkbox"/> Wash away from drainage facilities or water courses. <input type="checkbox"/> Discharge wash water to sanitary sewer. <input type="checkbox"/> Divert wash water to a treatment basin. <input type="checkbox"/> Make certain wash water runoff is clear. <input type="checkbox"/> Other:
Is a mobile washer used that results in discharge to an on-site storm drain?	<input type="checkbox"/> Yes <input type="checkbox"/> No	<input type="checkbox"/> Construct a wash rack for the washing area. <input type="checkbox"/> Berm the wash area to prevent run-on and runoff. <input type="checkbox"/> Wash away from drainage facilities or water courses. <input type="checkbox"/> Discharge wash water to sanitary sewer. <input type="checkbox"/> Make certain wash water runoff is clear. <input type="checkbox"/> Divert wash water to a treatment basin. <input type="checkbox"/> Other:
Does any other washing take place that may enter storm drains or affect stormwater quality?	<input type="checkbox"/> Yes <input type="checkbox"/> No	<input type="checkbox"/> Construct a wash rack for the washing area. <input type="checkbox"/> Berm the wash area to prevent run-on and runoff. <input type="checkbox"/> Discharge wash water to sanitary sewer. <input type="checkbox"/> Wash away from drainage facilities or water courses. <input type="checkbox"/> Divert wash water to a treatment basin. <input type="checkbox"/> Other:
Does any other washing take place that may run off-site?	<input type="checkbox"/> Yes <input type="checkbox"/> No	<input type="checkbox"/> Construct a wash rack for the washing area. <input type="checkbox"/> Berm the wash area to prevent run-on and runoff. <input type="checkbox"/> Wash away from drainage facilities or water courses. <input type="checkbox"/> Discharge wash water to sanitary sewer. <input type="checkbox"/> Divert wash water to a treatment basin. <input type="checkbox"/> Other:
If an oil/water separator is on site, is it in need of maintenance and/or cleaning?	<input type="checkbox"/> Yes <input type="checkbox"/> No	<input type="checkbox"/> Inspect, maintain, and/or clean the oil/water separator. <input type="checkbox"/> Other:

**If Answering "Yes" to any of the above questions refer to "Suggested Corrective Action Plan".**

# ACTIVITY SPECIFIC INSPECTION FORM

## Vehicles and Equipment Storage

**Complete this form only if related activities are conducted at this Fixed Facility**

Question	Answer Yes/No	If Answered Yes, Suggested Corrective Action Plan (See Model Maintenance Procedures for further Suggested Corrective Action Plans)		
<b>Storing Vehicles and Equipment</b>				
Are vehicles and/or equipment stored in an uncovered area with the potential to affect stormwater quality?	<input checked="" type="checkbox"/> Yes  <input type="checkbox"/> No	<input type="checkbox"/> Store vehicles and equipment in covered areas.		
		<input checked="" type="checkbox"/> If covered areas for storage are unavailable, inspect storage areas frequently for leaks and damage.		
		<input type="checkbox"/> Store vehicles and equipment away from drainage systems and waterbodies.		
		<input type="checkbox"/> Other:		
Do vehicles and/or equipment leak oil, or any other fluids?	<input checked="" type="checkbox"/> Yes  <input type="checkbox"/> No	<input type="checkbox"/> Use absorbent materials on small leaks rather than hosing down or burying. Remove absorbent materials promptly and dispose of properly.		
		<input checked="" type="checkbox"/> Use drip pan underneath equipment/vehicle.		
		<input checked="" type="checkbox"/> Stock appropriate clean-up materials.		
		<input checked="" type="checkbox"/> Inspect vehicles and equipment frequently for leaks.		
Is vehicle and/or equipment repair/maintenance performed near a storm drain?	<input type="checkbox"/> Yes  <input checked="" type="checkbox"/> No	<input type="checkbox"/> Designate maintenance areas away from drainage systems and water courses.		
		<input type="checkbox"/> Protect maintenance areas by placing a barrier around perimeter.		
		<input type="checkbox"/> Consider using portable tents or covers over maintenance areas.		
		<input type="checkbox"/> Do not dispose oil in dumpster, storm drain or waterbody.		
		<input type="checkbox"/> Other:		
		<b>Wrecked Vehicle Storage</b>		
		Are wrecked vehicles stored near storm drain inlets?	<input type="checkbox"/> Yes  <input checked="" type="checkbox"/> No	<input type="checkbox"/> Store vehicles away from drainage facilities or water courses.
				<input type="checkbox"/> Place drip pans under vehicles immediately.
<input type="checkbox"/> Drain all fluids, including air conditioner coolant.				
<input type="checkbox"/> Cover vehicles with plastic and secure firmly.				
		<input type="checkbox"/> Dispose of and transfer fluids properly.		
		<input type="checkbox"/> Other:		
		<b>Cleaning Vehicle Storage Areas</b>		
		Do non-stormwater discharges occur, such as shop floor washing, or water leakage from equipment?	<input type="checkbox"/> Yes  <input checked="" type="checkbox"/> No	<input type="checkbox"/> Store equipment away from drainage facilities or water courses.
<input type="checkbox"/> Place sandbags around inlets, drainage facilities and water courses.				
<input type="checkbox"/> Clean area with mechanical sweeper, rather than hosing.				
<input type="checkbox"/> Post water quality awareness signage for employees.				
		<input type="checkbox"/> Contain water and haul for treatment.		
		<input type="checkbox"/> Other:		

**If Answering "Yes" to any of the above questions refer to "Suggested Corrective Action Plan".**

# ACTIVITY SPECIFIC INSPECTION FORM

## Waste Handling and Disposal

**Complete this form only if related activities are conducted at this Fixed Facility**

Question	Answer Yes/No	If Answered Yes, Suggested Corrective Action Plan (See Model Maintenance Procedures for further Suggested Corrective Action Plans)
<b>Controlling Litter</b>		
Have self generated solid wastes been allowed to litter the Fixed Facility?	<input type="checkbox"/> Yes  <input type="checkbox"/> No	<input type="checkbox"/> Provide waste containers in convenient places, such as transit stops, for employees and the public.
		<input type="checkbox"/> Use enclosed trash containers to limit contact with wind and rain and prevent spillage.
		<input type="checkbox"/> Collect trash regularly to prevent spillage, especially during rainy and windy conditions.
		<input type="checkbox"/> Post "No Littering" signs.
		<input type="checkbox"/> Other:
<b>Waste Collection</b>		
Is the waste area littered and/or not well maintained?	<input type="checkbox"/> Yes  <input type="checkbox"/> No	<input type="checkbox"/> Regularly inspect solid waste containers for structural damage and repair or replace damaged containers as necessary.
		<input type="checkbox"/> Designate separate waste containers for wastes that can cause chemical reactions and complicate recycling or disposal.
		<input type="checkbox"/> Prevent any wastes other than solid wastes from being disposed of in the waste container.
		<input type="checkbox"/> Sweep and clean up spills in the waste management area immediately, using dry methods when possible.
		<input type="checkbox"/> Other:
Are staff unaware of their roles and responsibilities for hazardous waste handling or during a hazardous waste spill?	<input type="checkbox"/> Yes  <input type="checkbox"/> No	<input type="checkbox"/> Contact the local HAZMAT office or Fire Department for hazardous waste labeling regulations.
		<input type="checkbox"/> Contact the local HAZMAT office or Fire Department ask who should be contacted in case of a hazardous spill.
		<input type="checkbox"/> Develop hazardous waste storage and handling procedures.
		<input type="checkbox"/> Determine roles and responsibilities of employees and supervisors.
		<input type="checkbox"/> Designate authorized hazardous waste collection areas on-site.
		<input type="checkbox"/> Obtain permit for hazardous waste storage for more than 90 days.
		<input type="checkbox"/> Stencil storm drains on the Fixed Facility.
<input type="checkbox"/> Other:		
Is the amount of waste generated more than necessary, and is waste not being recycled?	<input type="checkbox"/> Yes  <input type="checkbox"/> No	<input type="checkbox"/> Recycle materials whenever possible.
		<input type="checkbox"/> Establish source controls.
		<input type="checkbox"/> Establish a material usage tracking system to increase awareness.
		<input type="checkbox"/> Other:

<b>Spill/Leak Control</b>		
Does the Fixed Facility lack a spill prevention program?	<input type="checkbox"/> Yes <input type="checkbox"/> No	<input type="checkbox"/> Identify staff members responsible for developing a spill prevention program. <input type="checkbox"/> Research other Fixed Facilities with spill prevention programs and use as a guideline. <input type="checkbox"/> Know who to contact if large or hazardous spills occur. <input type="checkbox"/> Other:
Have any spills occurred at the waste loading area over the past year that contributed pollutants to stormwater?	<input type="checkbox"/> Yes <input type="checkbox"/> No	<input type="checkbox"/> Develop a spill prevention plan for loading and unloading and transporting waste. <input type="checkbox"/> Repair or replace leaking containers or equipment and transfer waste from damaged containers to safe containers. <input type="checkbox"/> Regularly inspect and replace faulty pumps or hoses on solid waste containers that utilize a hydraulic fluid pump system. <input type="checkbox"/> Remove absorbent materials promptly and dispose of properly. <input type="checkbox"/> If large spill occurs, notify manager immediately and contain spread of spill. <input type="checkbox"/> Stock appropriate clean-up materials. <input type="checkbox"/> Other:
Do non-stormwater discharges occur in this area, such as water draining from stored wastes?	<input type="checkbox"/> Yes <input type="checkbox"/> No	<input type="checkbox"/> Perform activity away from drainage facilities or water courses. <input type="checkbox"/> Place sandbags around inlets, drainage facilities and water courses. <input type="checkbox"/> Contain and haul drainage for proper disposal. <input type="checkbox"/> Other:
<b>Runon/Runoff Prevention</b>		
Can stormwater run through stored wastes and carry pollutants into drainage ways?	<input type="checkbox"/> Yes <input type="checkbox"/> No	<input type="checkbox"/> Designate storage areas away from drainage system or water course. <input type="checkbox"/> Place a barrier around perimeter of waste management area (berm, sandbags, silt fence). <input type="checkbox"/> Place plastic cover over stored waste. <input type="checkbox"/> Store waste materials in a shed. <input type="checkbox"/> Cover dumpsters. <input type="checkbox"/> Inspect storage areas before and after rainfall events, and at least weekly all other times. <input type="checkbox"/> Place sandbags around inlets, drainage facilities and water courses. <input type="checkbox"/> Store hazardous waste materials on pallet or in secondary containment and cover. <input type="checkbox"/> Minimize the amount of waste stored on-site. <input type="checkbox"/> Other:

**If Answering "Yes" to any of the above questions refer to "Suggested Corrective Action Plan".**

Exhibit A-5.IV

Integrated Pest Management Program



# INTEGRATED PEST MANAGEMENT (IPM) POLICY & IMPLEMENTATION GUIDELINES FOR THE CITY OF ORANGE

## \*IPM POLICY - GENERAL BACKGROUND:

For the last 55 years, the trend in pest management has increasingly relied on synthetic chemical pesticides. The result has been not only a tremendous increase in the use of many dangerous chemicals, but also an increase in the number of pests that are resistant to the pesticides or new organisms becoming pests. Additionally, some pesticides used for terrestrial pest management have been found in waterways causing problems in the aquatic environment.

Pest control managers are now moving away from their reliance on pesticides alone toward an integrated approach that combines limited pesticide use with more environmentally friendly pest control techniques. This system is known as integrated pest management (IPM), a strategy that focuses on the long-term prevention of pests or their damage through a combination of techniques, including preventative, cultural, mechanical, environmental, biological, and chemical control tactics (**Figure 1**). The techniques are utilized simultaneously to control pest populations in the most effective manner possible.

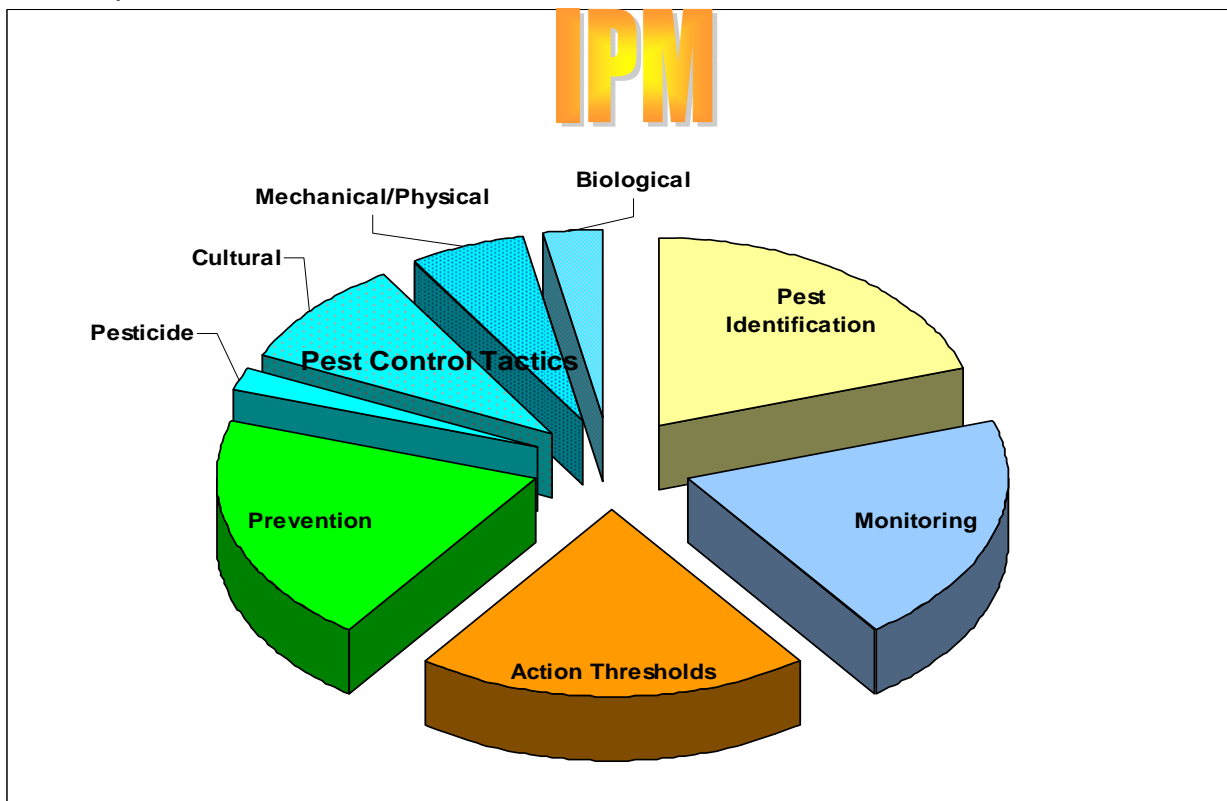

**Figure 1: Components of an Integrated Pest Management Program**

## **The Goal of IPM Policy and Program**

The goal of IPM is not to eliminate all pests, but to keep their populations at tolerable levels. Pesticides may be part of an IPM program, but they should only be used after the pests exceed established thresholds and only applied in the affected area (in the case of disease prevention, some modifications may be allowed). In general, all pest control strategies should be those that are least disruptive to biological control organisms (natural enemies), least hazardous to humans and the environment (including non-target organisms), and have the best likelihood of long-term effectiveness.

Developing a comprehensive Integrated Pest Management (IPM) Program and approach allows us to focus on our primary efforts of pollution prevention. By monitoring and preventing pests as well as minimizing heavy pest infestations we can reduce the need for chemicals and/or multiple applications.

IPM programs utilize monitoring techniques and injury levels and economic thresholds to determine when to implement control strategies. Treatments are only used according to established guidelines after monitoring indicates that such treatment is appropriate. Pest control materials are selected and applied in a manner that minimizes risks to human health, beneficial and non-target organisms and the environment.

The use of pesticides is often a measure of last resort. Because of this, the management guidelines for pesticide use are presented in a separate section immediately following the IPM guidelines.

## **Scope of IPM Policy and Implementation Plan**

IPM practices are encouraged over the sole use of pesticides as the primary means of pest management (**Table 1**). As a part of the Municipal Activities Program Manual, the public agencies and their contractors should evaluate the non-chemical components of IPM before intensive use of pesticides.

**Table 1. Advantages and Disadvantages of a Pesticide-Based Program versus an IPM-Based Pest Control Program**

<u>Pesticide Based Pest Control</u>		<u>IPM Based Pest Control</u>	
<u>Advantages</u>	<u>Disadvantages</u>	<u>Advantages</u>	<u>Disadvantages</u>
Quick suppression of pests	Not long-term	Long-term control	It may take longer to see results
	Pest control is reactive	Can be proactive in pest control actions	Must establish thresholds
	Loss of natural controls. Often get outbreaks of other pests	Reduces disruption of natural enemies	
		Pesticides can be used (only used as last resort).	Must have knowledge of pesticides and their effects on other organisms.
Labor is only for spraying	Extra work in cleanup	Staff becomes knowledgeable of pests and injury symptoms	Labor is required for monitoring and scouting Training is required to identify pests and natural enemies.
Not much preparation or follow-up needed	Need a PCA recommendation	Pest management is more organized	Must maintain a record-keeping system.
	Pesticide safety issues for applicators, public, animals	Less exposure to pesticides	
	More pesticides in environment	Safer to the environment	
	Contamination of water bodies from runoff	Reduces contamination from runoff	

Pesticides should not be applied until pests are approaching damaging levels. Because this requires early detection of the pests, monitoring on a regular basis is extremely important and should also be used to determine if natural enemies are present and adequately controlling the pest. If possible, a person should be trained and assigned to scout the sites on a regular basis.

## **Components of an IPM Program**

An IPM program is a long-term, multi-faceted system to manage pests (See **Figure 1**, on page 1). Use of pesticides is a short-term solution to pest problems and should be used only when the other components fail to maintain the pests or their damage below an acceptable level. Successful IPM practitioners are knowledgeable about the biology of the plants and pests and successful IPM programs primarily use combinations of cultural practices as well as a combination of physical, mechanical and biological controls.

### Pest Identification

It is important to learn to identify all stages of common pests at each site. For example, if you can identify weed seedlings, you can control them before they become larger and more difficult to control and before they flower, disseminating seeds throughout the site. It is also important to be sure that a pest is actually causing the problem. Often damage such as wilting is attributed to root disease but may actually be caused by under watering or wind damage.

### Prevention

Good pest prevention practices are critical to any IPM program, and can be very effective in reducing pest incidence. Numerous practices can be used to prevent pest incidence and reduce pest population buildup such as the use of resistant varieties, good sanitary practices and proper plant culture. Examples of prevention include choosing an appropriate location for planting, making sure the root system is able to grow adequately and selecting plants that are compatible with the site's environment.

### Monitoring

The basis of IPM is the development and use of a regular monitoring or scouting program. Monitoring involves examining plants and surrounding areas for pests, examining tools such as sticky traps for insect pests and quantitatively or qualitatively measuring the pest population size or injury. This information can be used to determine if pest populations are increasing, decreasing, or staying the same and to determine

when to use a control tactic. Weather and other environmental conditions may also play a factor in whether a pest outbreak may occur so, it is tantamount to monitor temperature and soil moisture.

It is important to use a systematic approach when monitoring, for example you should examine leaves of a similar age each time you check for pests, rather than looking at the older leaves on some plants and younger ones on others. Randomly looking at a plant and its leaves does not allow you to track changes in pest population or damage over time.

It is important to establish and maintain a record-keeping system to evaluate and improve your IPM program. Records should include information such as date of examination, pests found, size and extent of the infestation, location of the infestation, control options utilized, effectiveness of the control options, labor and material costs.

### Injury Levels and Action Thresholds

In order to have a way to determine when a control measure should be taken, injury levels and action thresholds must be set for each pest. An injury level is the level of unacceptable damage. For example, the injury level for a leaf-feeding beetle may be set at 30% of the leaves being damaged. Action thresholds are the set of conditions required to trigger a control action. An example of this would be finding an average of 5 or more beetles on 10 shrubs in a location. Action thresholds are set from previous experience or published recommendations and based on expected injury levels. Injury levels are often set by the public's comments.

### Pest Control Tactics

Integrated pest management programs use a variety of pest control tactics in a compatible manner that minimizes adverse effects to the environment. A combination of several control tactics is usually more effective in minimizing pest damage than any single control method. The type of control that an agency selects will likely vary on a case-by-case basis due to the varying site conditions.

The primary pest control tactics to choose from include:

- Cultural
- Mechanical/Physical
- Biological
- Pesticide

### *Cultural Controls*

Cultural controls are modifications of normal plant care activities that reduce or prevent pests. In addition to those methods used in the pest preventions, other cultural control methods include adjusting the frequency and amount of irrigation, fertilization, and mowing height. For example, spider mite infestations are worse on water-stressed plants, over-fertilization may cause succulent growth which then encourages aphids, too low of a mowing height may thin turf and allow weeds to become established.

### *Mechanical/Physical Controls*

Mechanical control tactics involve the use of manual labor and machinery to reduce or eliminate pest problems using methods such as handpicking, physical barriers, or machinery to reduce pest abundance indirectly. Examples include hand-pulling or hoeing and applying mulch to control weeds, using trap boards for snails and slugs, and use of traps for gophers.

The use of physical manipulations that indirectly control or prevent pests by altering temperature, light, and humidity can be effective in controlling pests. Although in outdoor situations these tactics are difficult to use for most pests, they can be effective in controlling birds and mammals if their habitat can be modified such that they do not choose to live or roost in the area. Examples include removing garbage in a timely manner and using netting or wire to prevent birds from roosting.

### *Biological Controls*

Biological control practices use living organisms to reduce pest populations. These organisms are often also referred to as beneficials, natural enemies or biocontrols. They act to keep pest populations low enough to prevent significant economic damage. Biocontrols include pathogens, parasites, predators, competitive species, and antagonistic organisms. Beneficial organisms can occur naturally or can be purchased and released.

The most common organisms used for biological control in landscapes are predators, parasites, pathogens and herbivores.

- Predators are organisms that eat their prey (e.g. Ladybugs).

- Parasites spend part or all of their life cycle associated with their host. Common parasites lay their eggs in or on their host and then the eggs hatch; the larvae feed on the host, killing it (e.g. tiny stingless wasps for aphids and whiteflies).
- Pathogens are microscopic organisms, such as bacteria, viruses, and fungi that cause diseases in pest insects, mites, nematodes, or weeds (e.g. *Bacillus thuringiensis* or BT).
- Herbivores are insects or animals that feed on plants. These are effective for weed control. Biocontrols for weeds are introduced herbivores that will eat seeds and leaves, or tunnel into plant stems (e.g. goats, sheep and some seed and stem borers).

In order to conserve naturally occurring beneficials, broad-spectrum pesticides should not be used since the use of these types of pesticides may result in secondary pest outbreak due to the mortality of natural enemies that may be keeping other pests under control (see **Figure 2**, below).

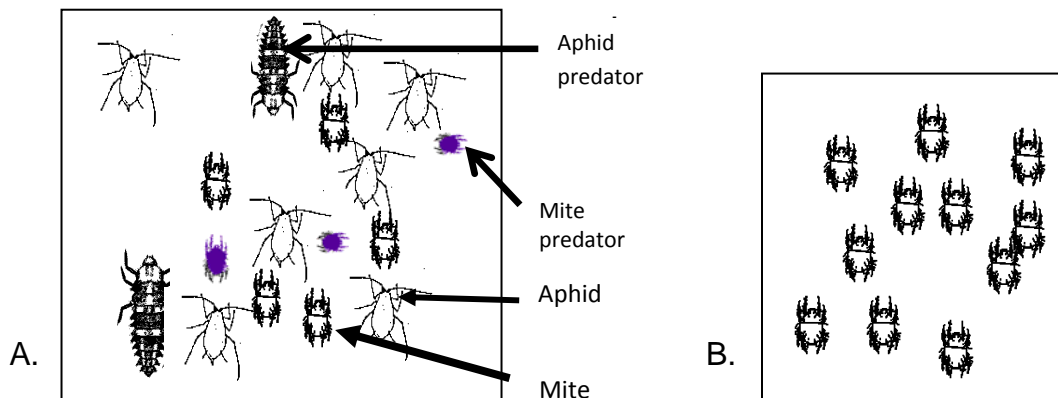

- A. Aphids and mites controlled by predators;  
 B. After a broad spectrum spray for aphids, predators for mites and aphids are also killed, resulting in an outbreak of mites.

**Figure 2: Example of Secondary Pest Outbreak Caused By Use of a Broad Spectrum Insecticide**

## *Pesticide Controls*

Any substance used for defoliating plants, regulating plant growth or preventing, destroying, repelling or mitigating any pest, is a pesticide. Insecticides, miticides, herbicides, fungicides, rodenticides and molluscides are all pesticides. Anything with an EPA or DPR registration number on the label is a non-exempt pesticide.

Pesticides should only be used when other methods fail to provide adequate control of pests and just before pest populations cause unacceptable damage. The overuse of pesticides can cause beneficial organisms to be killed and pest resistance to develop. When pesticides must be used, considerations should be made for how to use them most successfully. Avoid pesticides that are broad-spectrum and relatively persistent since these are the ones that can cause the most environmental damage and increase the likelihood of pesticide resistance. Always choose the most specific but least toxic to non-target organisms method.

In addition, considerations should be given to the proximity to water bodies, irrigation schedules, weather (rain or wind), etc. that are secondary factors that may result in the pesticide being moved off-site into the environment. Consideration should be made of the temporary loss of use of an area (application in a park may result in the area being sectioned off)



## **IMPLEMENTATION GUIDELINES:**

### **Designated IPM Contact Person:**

Dana Robertson, Parks & Facilities Manager  
Community Services Department  
City of Orange  
230 East Chapman Avenue  
Orange, CA 92866  
(714) 744-7283

Personnel responsible for the care and maintenance of facilities under the above-mentioned jurisdiction agree to implement a combination of basic integrated pest management procedures selected from the following five main components of an IPM program:

#### **I. PREVENTION**

#### **II. PEST and SYMPTOM IDENTIFICATION**

#### **III. MONITORING for PESTS and PROBLEMS**

#### **IV. ACTION THRESHOLDS and GUIDELINES**

#### **V. SELECTION of APPROPRIATE MANAGEMENT METHODS (Control Tactics)**

The procedures seek to increase the long-term prevention and suppression of pest problems (insects, weeds, diseases, and vertebrates) with the minimum impact on human health, the environment, and non-target organisms. Emphasis is placed on improving cultural practices to prevent problems and utilizing specific alternative control measures instead of broad spectrum pesticides.

Information on the latest IPM information including management of new pests in the landscape is obtained from local UC Cooperative Extension Advisors, UC IPM Regional Advisor, or the Statewide UC IPM Web Site at [www.ipm.ucdavis.edu](http://www.ipm.ucdavis.edu).

## I. PREVENTION

### A. Landscape Design Procedures

- 1) Drainage, soil characteristics, water quality and availability are considered during plant selection.
- 2) Sun exposure, heat, and high temperature conditions are considered during plant selection.
- 3) Adequate space is allowed for root growth, especially trees.
- 4) Nursery stock is inspected and rejected if not healthy (injuries, diseased, circling roots/pot-bound, poor staking and/or pruning).
- 5) Plants with similar growth characteristics and irrigation requirements are grouped together.
- 6) Landscape design matches available irrigation technology to avoid excess water use and to minimize surface runoff.

### B. Site Preparation and Planting Procedures *(a minimum of three must be selected)*

- 1) Assess soil drainage properties and improve compacted soils prior to planting.
- 2) Conduct a soil analysis to determine chemical and physical properties of the existing soil and then add appropriate amendments such as organic matter.
- 3) Ensure irrigation is installed as designed in order to avoid poor uniformity once plants are in place.
- 4) Follow proper planting procedures for particular plant species to avoid planting too deeply or too shallow.
- 5) Nursery tree stakes are removed at planting and replaced with staking that allows trunk to flex; removing these stakes after 1 to 1.5 years.

### C. Water Management

- 1) Monitor soil moisture with a soil probe or soil moisture sensors to assist in scheduling irrigation.
- 2) Utilize evapotranspiration (ET) data or 'smart' clock technology to schedule irrigation.
- 3) Cyclic irrigation (short-multiple run times) is employed to minimize surface runoff.
- 4) Utilize low precipitation sprinklers or low-volume systems to reduce surface runoff.
- 5) Systems are inspected weekly to check for leaks, broken pipes, and clogged or broken sprinkler heads.
- 6) Establish a hotline or email or other dedicated method where citizens can report leaks and broken sprinkler heads

### D. Fertilizing Procedures

- 1) Fertilize only when plants are actively growing to avoid nutrient losses below the root zone.
- 2) Fertilizer is not applied within 48 hours of a rain event to avoid losses below the root zone and in surface runoff.
- 3) Soil analyses are conducted in order to determine existing nutrient levels in the soil prior to fertilizing.
- 4) Turf grass fertilizer maintenance schedules are based on UC recommendations found online at UC Guide for Healthy Lawns.  
<http://www.ipm.ucdavis.edu/TOOLS/TURF/MAINTAIN/fertilize.html>
- 5) Sports turf grass fertilizer maintenance guidelines are based on UC recommendations found in **Establishing and Maintaining the Natural Turf Athletic Field (UCR ANR Publication Number: 21617)**.

- 6) Off-target fertilizer applications or spills are cleaned up immediately by sweeping up and applying to landscape or turf or replacing in spreader or bag to ensure material does not enter storm drains.

### **E. Pruning Procedures**

- 1) Trees are pruned according to standards set forth by a professional tree care organization such as the International Society of Arboriculture.
- 2) The age and species of the plant is taken into account when determining the time of year to prune. For example, eucalyptus should be pruned in December and January when long-horned beetles are not active.
- 3) Tree height reduction is discouraged. When deemed necessary by a licensed arborist, the crown reduction method approved by a professional tree care organization is utilized. Topping is never done to reduce tree size. NO TOPPING OR 'HAT RACKING' IS PERMITTED.

## **II. PEST and SYMPTOM IDENTIFICATION**

### **A. Insects, Mites, and Snails and Slugs**

- 1) Field personnel are trained to recognize basic pests found in the landscape in the following groups: insects, mites, and mollusks.
- 2) A licensed Pest Control Adviser is on staff or hired to properly identify a pest and the symptoms caused by the pest.
- 3) Abiotic or nonliving factors (wind, sunburn, air pollution, etc...) are considered as possible causes of observed symptoms as well as biotic (living) factors.

## **B. Weeds**

- 1) Field personnel are trained to utilize weed life cycles to properly control weeds such as controlling crabgrass utilizing a pre-emergent herbicide applied in mid-January.
- 2) A licensed Pest Control Adviser is on staff or contracted to properly identify the pest.

## **C. Diseases**

- 1) Field personnel are trained to recognize common diseases or their signs/symptoms in the landscape.
- 2) A licensed Pest Control Adviser is on staff or contracted to properly identify the pest.

## **D. Vertebrates**

- 1) Field personnel are trained to recognize vertebrate pests and the damage they cause in the landscape.
- 2) A licensed Pest Control Adviser is on staff or contracted to properly identify vertebrate pest.

### **III. MONITORING for PESTS and PROBLEMS**

#### **A. Insect/Mollusk Monitoring Procedures**

- 1) Visually inspect plants for insects, mites, snail and slug damage at least monthly; recording results utilizing a method conducive to tracking changes and easy recall of data.

- 2) Soil-dwelling turf insects are brought to the surface for monitoring by flushing a specific area of soil (i.e. 2' x 2' grid) with plain water or a soapy water mixture.
- 3) The amount of honeydew (aphids) and frass (caterpillars) present is utilized as an indicator of population levels.

### **B. Weed Monitoring Procedures**

- 1) Landscapes are inspected at least 4 times a year (early winter, early spring, summer and early fall) for weeds in order to determine if and when a weed problem exists. Weed abatement inspections are conducted twice per year: the spring inspections start in March and the fall inspections begin in September.
- 2) Utilize site surveys to record the location, date, and severity of weed problem; recording results utilizing a method conducive to tracking changes and easy recall of data.

### **C. Disease Monitoring Procedures**

- 1) Landscapes are regularly checked for conditions, such as overwatering and injuries, which promote disease.
- 2) Landscapes are checked monthly, at a minimum, for disease symptoms and signs. Disease prone plants are checked more frequently.

### **D. Vertebrate Monitoring Procedure**

- 1) Landscapes are regularly inspected for vertebrate presence either by damage caused by animal, actual animal sightings, and/or droppings.
- 2) Records are kept of the absence or presence of actual vertebrates, the damage caused, and/or the presence or absence of droppings.

## **IV. ACTION THRESHOLDS and GUIDELINES**

### **A. Insect/Mollusk Thresholds and Guidelines**

- 1) Thresholds are based on levels where reasonable control of the pest can be achieved with minimum impact on the environment.

### **B. Weed Thresholds and Guidelines**

- 1) Weed tolerance levels are established based on public safety statutes and regulations as enforced as necessary in the opinion of the Fire Code Official and Director of Public Works, the public's acceptance and the resources available to manage the landscape at that level.

### **C. Disease Thresholds and Guidelines**

- 1) Disease tolerance levels are established based on the public's acceptance and the resources available to manage the landscape at the level required.

### **D. Vertebrate Thresholds and Guidelines**

- 1) Vertebrate tolerance levels are established based on public safety, the public's acceptance and the resources available to manage the landscape at the level required.

## **V. SELECTION of APPROPRIATE MANAGEMENT METHODS (Control Tactics)**

### **A. Insect/Mollusk Management Methods**

#### ***A.1 Cultural/Mechanical/Physical Control Methods***

- 1) Small insect infestations are removed by pruning infested plant parts.

- 2) Plant canopies are thinned to increase light penetration to exposure certain soft-bodied insects (soft-scale) as well as snails and slugs to heat.
- 3) Avoid use of plants that snails and slugs use for shelter.

## **A.2 Biological Control Methods**

- 1) Persistent broad-spectrum pesticides are avoided, especially if biological control of an insect has been established by UC researchers. Examples include parasitoid wasps controlling Eugenia Psyllids, Giant Whitefly, and Ash Whitefly.

## **A.3 Pesticide Control Methods**

- 1) If available for controlling a particular insect, biological and botanical pesticides are selected
- 2) Pesticides are only utilized when the potential for impacts to the environment, especially water quality, are minimized.
- 3) Equipment is calibrated prior to the application of the insecticide to avoid excess material being applied to the landscape environment.
- 4) Applicators are trained to not apply pesticides to hard surfaces and to not allow any pesticide to enter the storm drain system
- 5) Spot treatments are utilized rather than broadcast methods
- 6) Insecticide/fertilizer combinations are only used if appropriate timing for BOTH the insecticide application and the fertilizer application.

## **B. Weed Management Methods**

### **B.1 Cultural, Mechanical, and Physical Control Methods**

- 1) Timers are set to avoid overwatering as weeds establish in areas where soil moisture is excessive.



- 2) Weeds are removed from a site prior to planting.
- 3) Mower height is adjusted to turf species and time of year.
- 4) Bare soil areas are covered with a thick layer of mulch to suppress weeds and conserve soil moisture.

## **B.2 Pesticide Control Methods**

- 1) Spot treatments are utilized rather than broadcast methods.
- 2) Herbicide/fertilizer combinations are only used if appropriate timing for BOTH the herbicide application and the fertilizer application.
- 3) Equipment is calibrated prior to the application of the herbicide to avoid excess material being applied to the landscape environment.

## **C. Disease Management Methods**

### **C.1 Cultural, Mechanical, and Physical Control Methods**

- 1) Prune out and dispose of localized areas of diseased plants.
- 2) Proper irrigation and fertilization are maintained to prevent plant stress, water-logging, and subsequent susceptibility to disease.
- 3) Mulch is kept at least 6" from base of plants to avoid excessive moisture around crown possibly resulting in crown rots and is no deeper than 4"
- 4) Replace disease-prone plants with non-susceptible species.

### **C.2 Pesticide Control Methods**

- 1) Synthetic fungicides are used sparingly in the landscape and only in high visibility areas in order to minimize development of resistance.
- 2) Fungicides classes are rotated to avoid resistance.

## **D. Vertebrate Management Methods**

### ***D.1 Cultural and Physical Control Methods***

- 1) Groundcovers are maintained such that they do not harbor rats.
- 2) Sources of drinking water removed (leaky faucets, puddles).
- 3) Kill traps used for ground squirrels and rabbits, are checked daily, and in places not accessible by children or non-target animals.
- 4) Gas cartridges are used for ground squirrels according to UC recommendations.

### ***D.2 Pesticide Control Methods***

- 1) Bait is applied in a manner that non-target animals do not access to it.
- 2) Restricted use rodenticides, aluminum or zinc phosphide, are used only after applicator has been trained for that product or only by a wildlife management contractor.

## **General Pesticide Management Practices**

- A. Restricted use pesticides are only used when no other alternatives are practical.
- B. If pesticides are necessary, CAUTION-labeled pesticides are considered before more toxic alternatives.
- C. Only small quantities of pesticides are purchased eliminating the need for stockpiling.
- D. MSDSs are regularly updated to reflect new pesticides or label changes to pesticides in storage.

## **Appendix A**

### **Ranking public areas for weeds (or other pest) management:**

Areas ranked as **HIGH** may include areas that the public sees and expects to be well-maintained. Examples are entrances to public buildings such as city hall and libraries.

*These areas are allowed to use pesticides based on established thresholds.*

Areas ranked as **MEDIUM** may include areas the public sees but does not expect a high level of maintenance. Examples are landscaped areas away from the entrance, recreational and picnic areas. These areas can tolerate a higher level of weeds.

*These areas are allowed to use pesticides but the threshold is much higher and pesticides are used infrequently and only after consultation with IPM coordinator.*

Areas ranked as **LOW** may include areas the public rarely sees or does not expect a high level of maintenance. Examples are medians, landscaped areas in parking lots, and wild lands. These areas can tolerate a higher level of weeds. Nothing in these guidelines shall supersede or modify public safety statutes and regulations, including but not limited to those enforced by the Fire Code Official and Director of Public Works.

*These areas are not allowed to use pesticides except in extreme cases and only after consultation with IPM coordinator.*